

# DTL08

## Compact calorimetric mass flow sensor for air

- **Current and voltage outputs for mass flow rate**
- **Limit switch**
- **Additional analog output for temperature**
- **Causes negligible pressure drop**
- **No moving parts**
- **Unaffected by duct diameter, pressure and temperature**



### Description:

Model DTL08 mass air flow sensors function according to the proven-reliable calorimetric principle. The sensor tip contains a resistor which is electronically heated. The air flowing around the sensor tip removes heat from it, thus changing its electrical resistance value. A second, unheated resistor detects the air temperature. The temperature difference between both resistors is proportional to the flow rate and thus to the flow volume. Model DTL08 mass air flow sensors are microprocessor based and come standard with linear analog outputs for flow rate and temperature as well as a limit contact.

### Typical Applications:

Model DTL08 mass air flow sensors are economical, high-performance units. These devices are used in applications where the flow of straight, non-turbulent air streams has to be measured or monitored. Such applications include the following: HVAC, air-supply systems, air-compressor monitoring, air-consumption measurement, leak monitoring, cooling circuits, and the like.

## Models:

**DTL08.ALS ...:** Linear analog output for air flow  
Linear analog output for temperature  
Switch output for flow

## Dimensions:

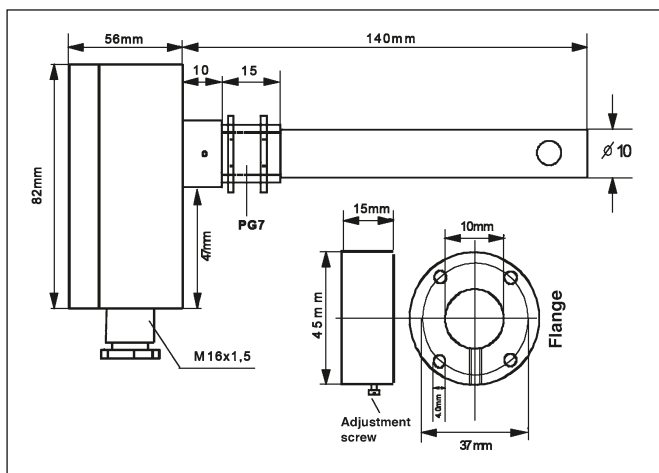

## Electrical connection:

### 10 pin terminal strip:

Pin	assignments
1	+24 VDC
2	Ground
3	0–10 V analog output air temperature (+)
4	0–10 V analog output air flow stream (+)
5	4–20 mA analog output air flow stream (–)
6	4–20 mA analog output air flow stream (+)
7	Transistor output (O/C signal)
8	Relay output (normally closed (N/C))
9	Relay output (normally closed (N/C))
10	Not assigned

## Model Coding:

**Order Number:** DTL08. ALS. 30. 1. 0

**Calorimetric mass air flow sensor**

### Models:

ALS = Analog outputs for flow and temperature, limit contact

### Measuring range:

01 = 0–1 m/s  
08 = 0–8 m/s  
16 = 0–16 m/s  
30 = 0–30 m/s

### Process connection

1 = PG7 conduit thread (7 mm)  
2 = Mounting flange  
3 = M16 x 1.5 male thread (with adapter)  
4 = G 1/2 male thread (with adapter)

### Options:

0 = none  
9 = please specify in writing

## Technical Specifications:

	DTL08.ALS
<b>Measuring range</b>	0–1 m/s, 0–8 m/s, 0–16 m/s, 0–30 m/s
<b>Analog output: flow</b>	4–20 mA (Ra = 200 Ohm) 0–10 V (Ra = 10 kOhm)
<b>Analog output: temp.</b>	0–10 V (Ra = 10 kOhm)
<b>Switch output</b>	Relay 200 VDC, 1 A, normally closed (N/C), Transistor output (O/C signal), non-conductive during flow
<b>Accuracy<sup>1)</sup></b>	± 5 % of measured range end value
<b>Reproducibility<sup>1)</sup></b>	± 2 %
<b>Temperature gradient</b>	30 K/min
<b>Power supply:</b>	24 VDC ± 5 %
<b>Power consumption max.</b>	4 VA
<b>Temperature range:</b>	Ambient: –20–+60 °C medium: –25–+80 °C
<b>Sensor:</b>	Max. pressure: 10 bar Material: Brass, nickel-plated Insertion depth: 130 mm (other sensor lengths on request) Diameter: 10 mm Process connection: PG7 conduit thread (7 mm, standard) Mounting flange; Adapter M16 x 1.5 or 1/2" male thread
<b>Electrical protection:</b>	meter housing: IP 65 sensor: IP 54
<b>Electronics housing:</b>	Material: Plastic Dimensions: L x W x H = 56 x 84 x 82 mm

<sup>1)</sup> Reference conditions: inlet pipe section > 10 x DN, outlet pipe section > 5 x DN, laminar, non-turbulent flow, air at standard conditions: 0 °C and 1.013 bar

**PKP Prozessmesstechnik GmbH**

Borsigstraße 24 · D-65205 Wiesbaden  
+49 (0) 6122-7055-0 · +49 (0) 6122-7055-50  
Email: info@pkp.de · Internet: www.pkp.de

**PKP Process Instruments Inc.**

10 Brent Drive · Hudson, MA 01749  
+1-978-212-0006 · +1-978-568-0060  
Email: info@pkp.eu · Internet: www.pkp.eu

