

DTH08

Low-volume calorimetric flow sensor

- **Measuring ranges: 0.16 – 32 GPH, 0.4 – 80 GPH and 0.8 – 160 GPH (0.01 – 2 l/min, 0.025 – 5 l/min and 0.05 – 10 l/min)**
- **Wetted parts made of stainless steel 1.4571**
- **No moving parts**
- **Very low pressure drop**
- **Easy handling**



Description:

The model DTH08 calorimetric flow sensor measures and monitors liquid flow. Its compact design makes it suitable for a wide variety of applications. Depending on the model, the device can be fitted with an analog output (4 – 20 mA or 0 – 10 V) and a switched or frequency output. The sensor measures the flow rate and temperature of the liquid. Both these parameters can be assigned to the analog output or the switched output (see table 1).

Typical Applications:

The DTH08 sensors are designed to economically measure and monitor the flow rates of aqueous liquids. They are a very good alternative to conventional flow sensors as they have very low flow resistance and are not adversely affected by contamination or soiling by solids.

Output combinations, Table 1

No.	Flow rate		Temperature	
	Analog	Switched output/ Frequency output	Analog	Switched output/ Frequency output
1	x			
2		x		
3	x	x		
4	x			x
5		x	x	

Dimensions:

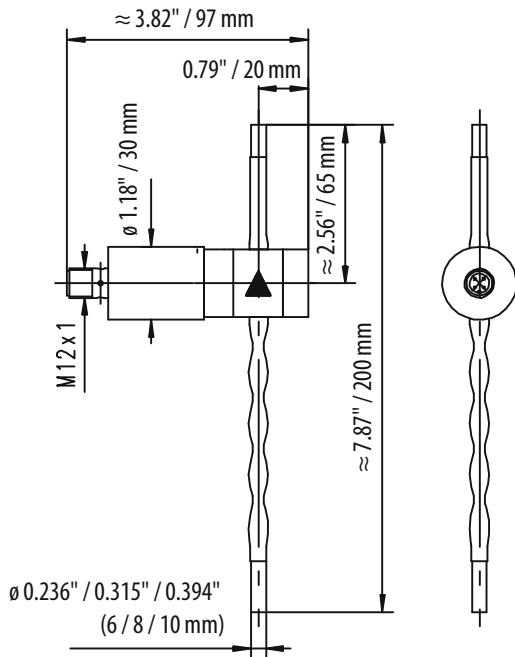

Electrical Specifications:

Voltage supply:	24 VDC \pm 10 %
Power consumption:	max. 100 mA
Switched output:	Push-pull transistor output (short-circuit proofed and reverse polarity protected) $I_{out} = 100$ mA max.
Switching hysteresis:	Flow rate: 1% f.s. Temperature approx.: 1 °C
Analog output:	4 – 20 mA / ohmic resistance 500 Ohm max. or 0 – 10V / load min. 1 K Ohm

Typenschlüssel:

Order Number: DTH08 1. 1. 1. 0

Calorimetric flow sensor

Measuring ranges:

1 = 0.01 – 2 l/min 1U = 0.16 – 32 GPH
 2 = 0.025 – 5 l/min 2U = 0.4 – 80 GPH
 3 = 0.05 – 10 l/min 3U = 0.8 – 160 GPH
 S = Special measuring range

Analog or switched output combinations (see table 1):

1 = Analog output for flow rate
 2 = Switched output or frequency output for flow rate
 3 = Analog and switched output or frequency output for flow rate
 4 = Analog output for flow rate and switched output or frequency output for temperature
 5 = Switched output or frequency output for flow rate and analog output for temperature

Analog output:

1 = 4 – 20 mA standard
 2 = 4 – 20 mA inverted
 3 = 0 – 10 V standard
 4 = 0 – 10 V inverted

Switching signal:

0 = no switched output
 1 = minimum switch point
 2 = maximum switch point
 3 = frequency output, max. 2000 Hz

Technical Specifications:

Process connection:	pipe connection, dia. = 0.236" / 0.315" / 0.394" (6/8/10 mm)
max. pressure:	150 psi / 10 bar (other pressures available on request)
Medium temperature:	32 – 158 °F / 0 – 70 °C
Temperature gradient:	8 °F / 4 °C per second
Accuracy:	\pm 5 % of measured value
Linearity:	\pm 2 %
Pressure drop:	max. 4.35 psi / 0.3 bar at maximum flow rate
Electrical connection:	plug connector, M12x1, 4-pin to DIN
Ingress protection:	IP 40