

# DS25

## Variable Area Flowmeter With Flange Connection, Insensitive To Viscosity Changes

- for liquids and gases
- operating pressure PN40 and PN100 bar standard, higher pressures up to 320 bar on request
- operating temperatures up to 370 °C
- individual calibration for all operating conditions
- local indication, min. - max. alarms, analogue output
- measuring tube completely stainless steel 1,4404
- PTFE coating for wetted parts optionally

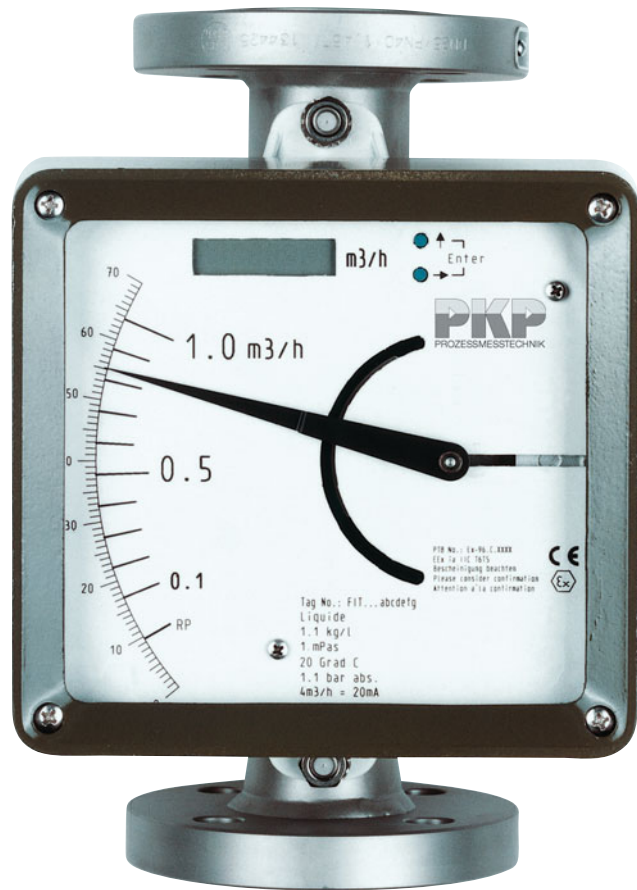

### Description:

The flow meters model DS25 work according to the proven variable area principle. The float is guided in a conical measuring tube and is nearly independent of the viscosity of the medium. The flowing medium moves the float in the flow direction. An externally mounted pointer indicator is magnetically coupled to the float and thus, following the float position, indicates the flow rate on a scale. This indicator assembly is equipped with a scale calibrated to the operating conditions in the system and additionally may contain alarm contacts or an analog output.

### Application:

The variable area flowmeter model DS25 is used for measuring and monitoring the flow of all kinds of liquids and gases. By using only stainless steel 1,4571 for the wetted parts the meter is especially suited for aggressive media or for use in food and drink applications (with Tri-Clamp or other hygienic process connections)

## Meter selection procedure:

1. Define materials of wetted parts
2. Select process connection (table 2)
3. Select measuring range
4. Select indicator and output signals
5. Select options

## 1. Material version (wetted parts):

The flow meters model DS25 may be supplied either completely in stainless steel 1.4571 (DS25.1) or with PTFE-coating (DS25.2)

Other materials like Monel, Hastelloy or Tantal on request (DS25.9)

## 2. process connection:

Nom. bore (NB)	process connection	Meas. tube No.	Conn. Code No.	Length L (mm)
15 (1/2")	Flanges DN15 PN40	1	101	250
	Flanges ANSI 1/2" 150 lbs.	1	102	250
	Flanges ANSI 1/2" 300 lbs.	1	103	250
	G 1/2 IG	1	104	295
	1/2" NPT IG	1	105	295
	Flanges DN15 PN40	2	206	250
	Flanges ANSI 1/2" 150 lbs.	2	207	250
	Flanges ANSI 1/2" 300 lbs.	2	208	250
20 (3/4")	Flanges DN20 PN40	1	111	250
	Flanges ANSI 3/4" 150 lbs.	1	112	250
	Flanges ANSI 3/4" 300 lbs.	1	113	250
	Flanges DN20 PN40	2	216	250
	Flanges ANSI 3/4", 150 lbs.	2	217	250
	Flanges ANSI 3/4", 300 lbs.	2	218	250
	G 3/4 IG	2	219	250
	3/4" NPT IG	2	220	250
25 (1")	Flanges DN25 PN40	1	121	250
	Flanges ANSI 1" 150 lbs.	1	122	250
	Flanges ANSI 1" 300 lbs.	1	123	250
	threaded conn. DN25 PN40 (IG) to DIN 11851	1	126	275
	Tri-Clamp DN25 / 1"	1	127	250
	Flanges DN25 PN40	2	228	250
	Flanges ANSI 1" 150 lbs.	2	229	250
	Flanges ANSI 1" 300 lbs.	2	230	250
	threaded conn. DN25 PN40 (IG) to DIN 11851*	2	233	275
	Tri-Clamp DN25 / 1"	2	234	250
	Flanges DN25 PN40	3	335	250
	Flanges ANSI 1", 150 lbs.	3	336	250
	Flanges ANSI 1", 300 lbs.	3	337	250
	G 1 IG	2	338	250
1" NPT IG	2	339	250	

Nom. bore (NB)	process connection	Meas. tube No.	Conn. Code No.	Length L (mm)
32 (1 1/4")	Flanges DN32 PN40	1	140	250
	Tri-Clamp DN32	1	141	250
	Flanges DN32 PN40	2	242	250
	Flanges ANSI 1 1/4" 150 lbs.	2	243	250
	Flanges ANSI 1 1/4" 300 lbs.	2	244	250
	Tri-Clamp DN32	2	245	250
	Flanges DN32 PN40	3	346	250
	Flanges ANSI 1 1/4", 150 lbs.	3	347	250
	Flanges ANSI 1 1/4", 300 lbs.	3	348	250
	G 1 1/4 IG	3	349	250
1 1/4" NPT IG	3	350	250	
40 (1 1/2")	Tri-Clamp DN40 / 1 1/2"	1	151	250
	Tri-Clamp DN40 / 1 1/2"	2	252	250
	Flanges DN40 PN40	3	353	250
	Flanges ANSI 1 1/2", 150 lbs.	3	354	250
	Flanges ANSI 1 1/2" 300 lbs.	3	355	250
	G 1 1/2 IG	3	364	250
	1 1/2" NPT IG	3	365	250
	Flanges DN50 PN40	3	356	250
50 (2")	Flanges ANSI 2" 150 lbs.	3	357	250
	Flanges ANSI 2" 300 lbs.	3	358	250
	Gewindestutzen DN50 PN25 (IG) to DIN 11851	3	359	275
	Tri-Clamp DN50 / 2"	3	360	250
	Flanges DN50 PN40	4	461	250
	Flanges ANSI 2" 150 lbs.	4	462	250
Flanges ANSI 2" 300 lbs.	4	463	250	
65 (2 1/2")	threaded conn. DN65 PN25 (IG) to DIN 11851	4	466	275
	G 2 1/2 IG	4	467	250
	2 1/2" NPT IG	4	468	250
	threaded conn. DN80 PN25 (IG) to DIN 11851	4	469	275
80	Tri-Clamp DN80 / 3"	4	470	300
	Flanges DN80 PN40	5	571	250
	Flanges ANSI 3", 150 lbs.	5	572	250
	Flanges ANSI 3", 300 lbs.	5	573	260
	threaded conn. DN100 PN25 (IG) to DIN 11851	5	574	300
	Tri-Clamp DN100 / 4"	5	575	250
100 (4")	Flanges DN100 PN16	6	676	250
	Flanges DN100 PN40	6	677	250
	Flanges ANSI 4", 150 lbs.	6	678	250

### 3. Measuring ranges:

Reference conditions: Water, 20°C  
Air, 20 °C, 1,013 bar abs.

#### a) DS25.1 - stainless steel version

Meas. tube No.	Range code	Water / Liquids					Air / Gases			
		Range (m <sup>3</sup> /h)	Meas.-cone No.	Float No.	pressure loss (mbar)	max. viscosity (mPas)	Range (Nm <sup>3</sup> /h)	Meas.-cone No.	Float No.	press. loss (mbar)
1	101	<b>0.0025-0.026</b>	43	S0	40	2.9	<b>0.075-0.75</b>	43	S0	45
	102	<b>0.004-0.04</b>	44	S0	40	4.5	<b>0.12-1.2</b>	44	S0	45
	103	<b>0.0063-0.063</b>	47	S0	40	6.4	<b>0.18-1.8</b>	47	S0	45
	104	<b>0.01-0.1</b>	51	S0	40	9.2	<b>0.3-3</b>	51	S0	45
	105	0.01-0.1	53	L1	6	5.1	-	-	-	-
2	206	0.01-0.1	53	L1	6	5.1	<b>0.55-5.5</b>	53	M1	20
	207	<b>0.016-0.16</b>	53	M1	15	8.2	<b>0.4-4</b>	53	L1	11
	208	0.016-0.16	54	L1	6	7.1	<b>0.65-6.5</b>	54	L1	11
	209	<b>0.025-0.25</b>	53	S1	40	13	0.75-7.5	53	S1	45
	210	0.025-0.25	57	L1	6	8.8	<b>1-10</b>	57	L1	11
	211	<b>0.04-0.4</b>	54	S1	40	18	1.3-13	54	S1	45
	212	0.04-0.4	61	L1	6	10	<b>1.6-16</b>	61	L1	11
	213	<b>0.063-0.63</b>	57	S1	40	23	2-20	57	S1	45
	214	0.063-0.63	61	M1	15	17	<b>2.5-25</b>	62	L1	11
	215	<b>0.1-1</b>	61	S1	40	27	3-30	61	S1	45
	216	0.1-1	62	M1	15	19	<b>3.5-35</b>	62	M1	20
	217	<b>0.16-1.6</b>	62	S1	40	31	-	-	-	-
	218	<b>0.23-2.3</b>	62	V1	45	-	-	-	-	-
	3	319	0.1-1	63	L2	7	17	<b>4-40</b>	63	L2
320		0.16-1.6	64	L2	7	20	5-50	63	M2	22
321		<b>0.25-2.5</b>	63	S2	41	44	<b>7-70</b>	64	L2	12
322		0.25-2.5	64	M2	16	16	<b>9-90</b>	64	M2	22
323		<b>0.4-4</b>	64	S2	41	50	<b>13-130</b>	64	S2	47
324		<b>0.6-6</b>	64	V2	43	-	-	-	-	-
4	425	0.25-2.5	67	L5	8	29	<b>10-100</b>	67	L5	14
	426	0.4-4	71	L5	8	33	13-130	67	M5	25
	427	<b>0.63-6.3</b>	67	S5	47	72	<b>16-160</b>	71	L5	14
	428	0.63-6.3	72	L5	8	37	<b>20-200</b>	71	M5	25
	429	<b>1-10</b>	71	S5	47	82	20-200	67	S5	54
	430	1-10	72	M5	19	58	<b>28-280</b>	72	L5	14
	431	1.6-16	72	S5	47	92	36-360	72	M5	25
	432	<b>2.3-23</b>	72	V5	63	-	50-500	72	S5	54
5	533	<b>2.5-25</b>	73	V8	60	-	<b>50-500</b>	73	L8	30
	534	<b>4-40</b>	74	V8	60	-	75-750	73	V8	65
	535	<b>6-60</b>	77	V8	60	-	<b>85-850</b>	74	L8	30
	536	-	-	-	-	-	120-1200	74	V8	65
	537	-	-	-	-	-	180-1800	77	V8	65
6	638	<b>10-100</b>	81	11	70	-	-	-	-	
	639	<b>15-130</b>	81	12	-	-	-	-	-	

Whenever possible select highlighted ranges

**b) DS25.2 – wetted parts PTFE coated**

Meas. tube No.	Range code	Water / Liquids				Air / Gases			
		Range (m³/h)	Meas.- cone No.	Float No.	pressure loss (mbar)	Range (Nm³/h)	Meas.- cone No.	Float No.	press. loss (mbar)
2	250	0.01 - 0.1	51	A1	16	0.35 - 3.5	51	A1	20
	251	0.016 - 0.16	52	A1	16	0.5 - 5	52	A1	20
	252	0.025 - 0.25	53	A1	16	0.85 - 8.5	53	A1	20
	253	0.04 - 0.4	54	A1	16	1.3 - 13	54	A1	20
	254	0.063 - 0.63	57	A1	16	2 - 20	57	A1	20
	255	0.1 - 1	61	V1	18	3.4 - 34	61	V1	22
3	356	0.16 - 1.6	62	A2	20	5 - 50	62	A2	25
	357	0.25 - 2.5	63	A2	20	8.5 - 85	63	A2	25
	358	0.4 - 4	63	V2	22	-	-	-	-
4	459	0.4 - 4	64	A5	20	13 - 130	64	A5	25
	460	0.63 - 6.3	67	A5	20	20 - 200	67	A5	25
	461	1 - 10	71	A5	20	35 - 350	71	A5	25
	462	1.6 - 16	71	V5	22	-	-	-	-
5	563	1.6 - 16	72	V8	25	50 - 500	72	27	12
	564	2.5 - 25	73	V8	25	85 - 850	73	27	22
	565	4 - 40	74	V8	25	-	-	-	-
6	666	6.3 - 63	77	10	30	-	-	-	-

**Technical specifications (measuring tube):**

**measurable media:** liquids and gases

**ranges:** see tables 3a and 3b

**turndown ratio:** 10 : 1

**accuracy:**  
 DS25.1: 1.6% f.s.  
 DS25.2: 2.5% f.s.

**process connection:** see Table 2

**max. pressure:** see Table 2

**media temperature:**  
 DS25.1: -180°C...370°C  
 DS25.2: -80°C... 130°C  
 (the actual operating temperature also depends on the max. permissible temperatures for the indicator and the options utilized in the unit)

**materials:**  
 DS25.1: all wetted parts stainless steel (AISI 316 L)  
 DS25.2: all wetted parts stainless steel AISI 316 L with PTFE coating

**mounting:** vertical

**flow direction:** from bottom to top

**mounting length:** see table “process connection”

**straight pipe runs:**  
 DN 15-65 none  
 DN 80-100 min. 5D

**electrical protection:** IP 65

## 4. Indicator:

The indicator part of the DS25 consists of an aluminium or polyamide housing with a pointer assembly magnetically coupled to the float. The scale may be calibrated in flow units or in percent. Additionally, transducers and alarm contacts may be mounted in the indicator housing.

### 4a. Housing versions

Material:	Code No.
Polyamid	1
Aluminium	2

### 4b. Alarm contacts

Contact version:	Code No.
without	0
1 min contact	1
1 max contact	2
1 min. and 1 max. contact	3
2 max. contacts	5

### 4c. Analog output signals

Typ:	Code No.
without	0
electrical transducer	1
electrical transducer (Ex)	2
pneumatic transducer	3

### 4d. Supply voltage and output signals

Typ:	Code No.
without	00
115 VAC, 0...20 mA, 4-wire	01
115 VAC, 4...20 mA, 4-wire	02
230 VAC, 0...20 mA, 4-wire	03
230 VAC, 4...20 mA, 4-wire	04
24 VDC, 0...20 mA, 3-wire	07
24 VDC, 4...20 mA, 2-wire	08
24 VDC, 4...20 mA, 3-wire	09
24 VDC, 0...20 mA, 4-wire	10
24 VDC, 4...20 mA, 4-wire	11
pneumatic 0,2...1,0 bar	12
pneumatic 3...15 psi	13

## Technical specifications (indicator assembly):

### Mechanical indicator assembly

#### Umgebungstemperatur:

PA-housing (Code 1): -25°C ... 100°C

Al-housing (Code 2): -25°C ... 130°C

(for higher or lower operating temperatures use option "temperature isolation (DS25.A)" on next page)

### Alarm contacts

**model:** inductive proximity switch, SJ3,5-N acc. to DIN 19234 (NAMUR)

#### ambient temperature:

-25°C ... 100°C (for higher or lower operating temperatures use option "temperature isolation")

#### rated voltage:

8 VDC (Ri = 1 kOhm)

#### output signal:

≤1 mA = 0, ≥3 mA = 1

#### explosion protection:

EEx ia IIC T6, set II category 2G (on request)

#### dust explosion protection:

EEx iaD 20 T 108°C, set II category 1D

#### recommended accessories:

contact protection relay model SE01 (see "Options" on next page)

### Electronic transducer

**output signal:** 0...20 mA, 4-20 mA

**indication:** LCD display, 8 digits (programmable for indication of flow rate or as non-resettable totalizer)

**supply voltage:** see table 4d

**max. load:** 4-wire: ≥500 Ohm  
2/3-wire:  $\frac{U-13.5 V}{20 \text{ mA}}$

**operating temperature:** 0°C...100°C

(for higher or lower operating temperatures use option "temperature isolation (DS25.A)" on next page)

**electrical connection:** M16 X 1,5 or 1/2" NPT

### Intrinsically safe electronic transducer

Technical specifications as standard unit, however:

**output signal:** 4...20 mA, 2-wire

**operating temperature:** -25°C...70°C

(for higher or lower operating temperatures use option "temperature isolation (DS25.A)" on next page)

#### Ex-protection:

EEx ia IIC T6, set II category 2G (on request)

#### dust explosion protection:

EEx II 3D; set II; category 3D, max; surface temperature: 80 °C

#### recommended accessories:

intrinsically safe power supply (see "Options" on next page)

### Intrinsically safe electronic transducer

on request

## 5. Options

### 5a. Temperature isolation (DS25.A)

For media temperatures outside the limits given in the technical specifications for the indicator assembly the measuring tube and the indicator assembly may be temperature isolated by mounting the indicator at a distance of 60 mm apart from the measuring tube. This ensures that the unit may be operated at media temperatures as high as stated in the specifications for the measuring tube.

### 5b. Damping (DS25.D):

A float damping is recommended for gas applications to prevent erratic up and down movement (only for DS25.1).

### 5c. Heating:

Heating assemblies (steam jackets) are used to keep the medium in the measuring tube at a required temperature. Steam jackets are available with three different process connections:

Connection:	Code:
DIN flanges DN15 PN40	DS25.H.1
DIN flanges DN 25 PN 40	DS25.H.2
threaded conn. R 1/4"	DS25.H.3

### 5d. Oxygene applications (DS25.F):

For use with oxygene the meters may be supplied oil- and greese-free.

### 5e. Certificates

on request

### 5f. Tags:

Stainless steel tags with customer specified text are optionally available

### 5g. Contact protection relays (model SKF): SKF...

#### material version:

according to DIN 19234

#### supply voltage

according data specification SKF

#### breaking capacity

max. 250 VAC, max. 2 A

#### control circuit

intrinsically safe ( EEx ia ) IIC:

### 5h. Power supply for intrinsically safe transducer

(model SE11):

#### Output signal:

0 / 4...20 mA, galvanically separated

#### Supply voltage:

SE11.1: 230 VAC  
SE11.2: 24 V AC/DC

#### max. load:

750 Ohm

#### control circuit:

intrinsically safe [EEx ia] IIC

## Ordering Code

Order no.: DS25. 1. 121. 1. 321. 1. 0. 104.

### Variable area flowmeter

#### Material version:

1 = stainless steel  
2 = wetted parts PTFE coated

#### Process connection:

101...678 = according to table 2  
999 = special connection

#### Medium:

1 = water / liquids  
2 = air / gases

#### Measuring range:

101...666 = according to table 3a or 3b  
999 = special range

#### Indicator housing:

1...2 = according to table 4a

#### Alarm contacts:

0...5 = according to table 4b

#### Analog output and supply voltage:

1<sup>st</sup> digit:

0...3 = analog output according to table 4c

2<sup>nd</sup> and 3<sup>rd</sup> digit:

00...13 = supply voltage and output signal according to table 4d

**Options:** please indicate in writing

### Ordering Information:

Important: for complete identification of the meter the following information must be specified:

- order no. according to table above
- name of medium
- temperature (operational, max.)
- pressure (operational, max.)
- viscosity (for liquids only)
- specific gravity of medium
- for gases only: reference conditions
- options: model no. ac. to tables 5a. to 5h.
- additional customer specific information



**Dimensions:**

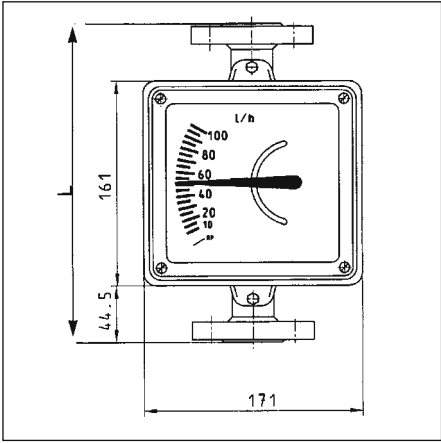

**Fig. 1: front view**

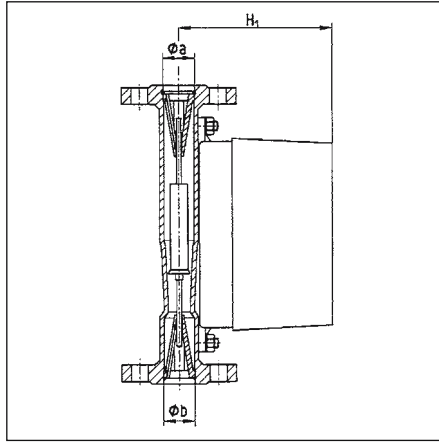

**Fig. 2: stainless steel measuring tube**

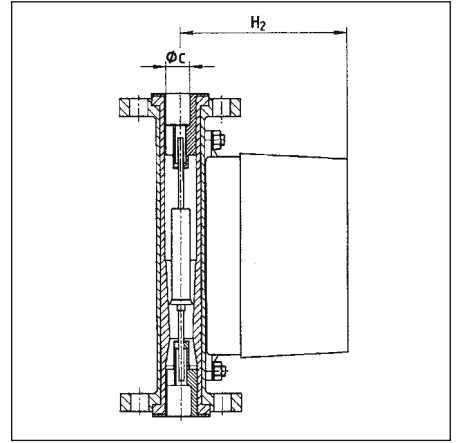

**Fig. 3: measuring tube PTFE coated**

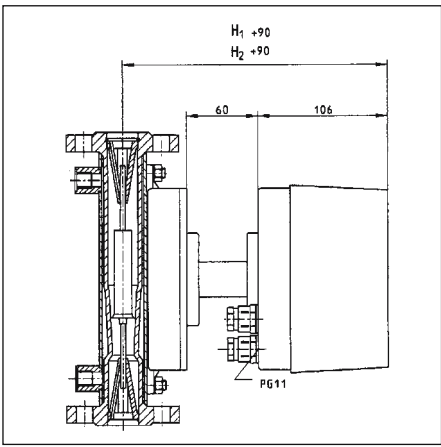

**Fig. 4: Option DS25.H... (steam jacket and DS25.A (temperature isolation)**

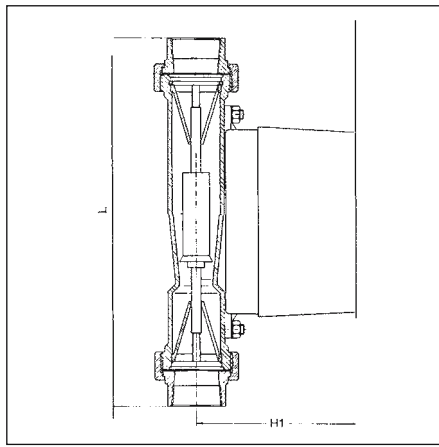

**Fig. 5: measuring tube with threaded connection (R or NPT)**

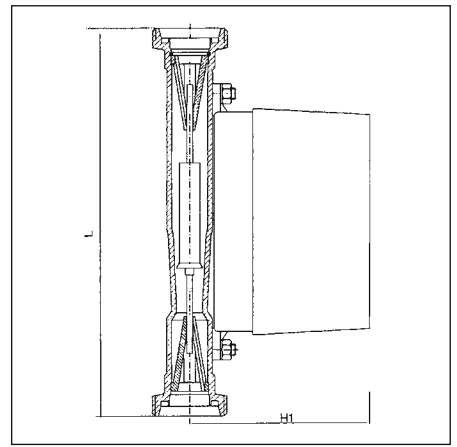

**Fig. 6: measuring tube with hygienic connection acc. to DIN 11851**

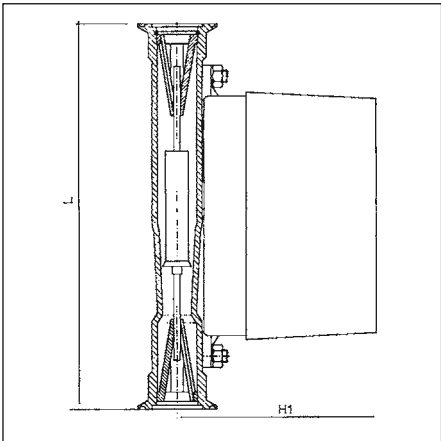
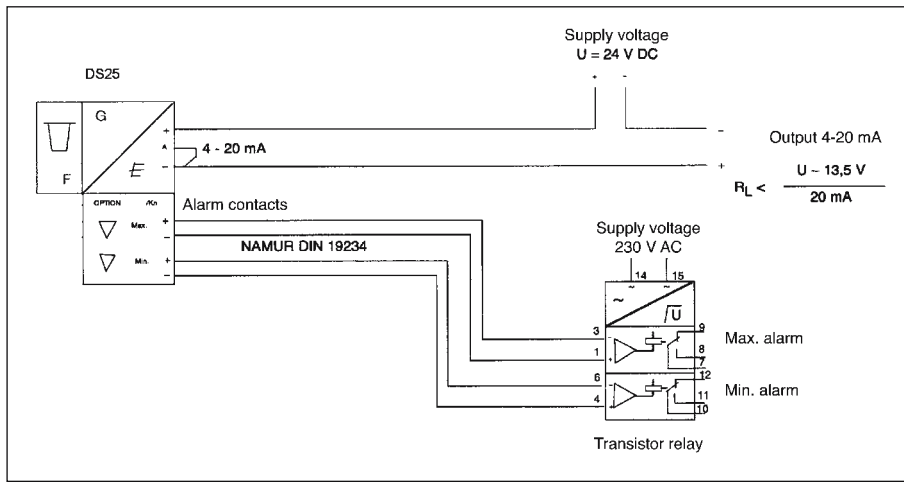

**Fig. 7: measuring tube with Tri-Clamp connection**

Measuring tube No.	H1 (mm)	H2 (mm)	Weight (kg)
1	122	122	5
2	123	127	5
3	131	136	6,5
4	147	152	11
5	161	168	16
6	170	176	20

Dimension "L": see table 2 (process connections)

## Electrical connections:



electronic transducer,  
2-wire

2 alarm contacts with  
contact protection relay

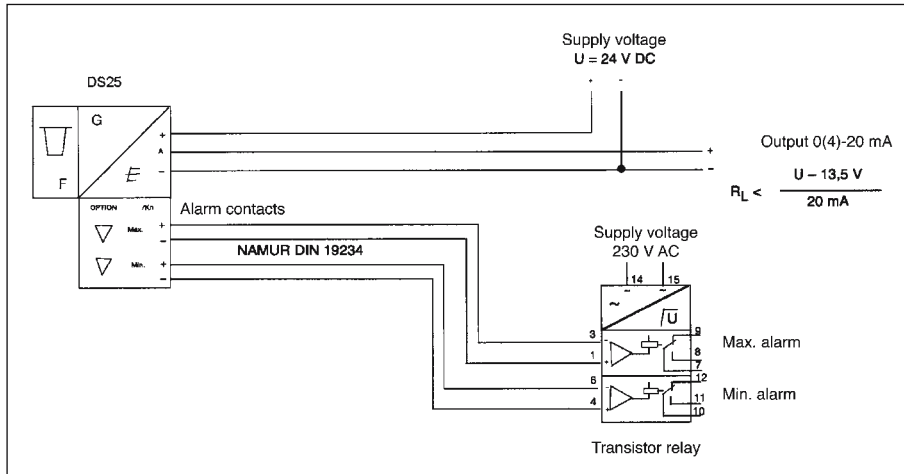

electronic transducer,  
3-wire

2 alarm contacts with  
contact protection relay

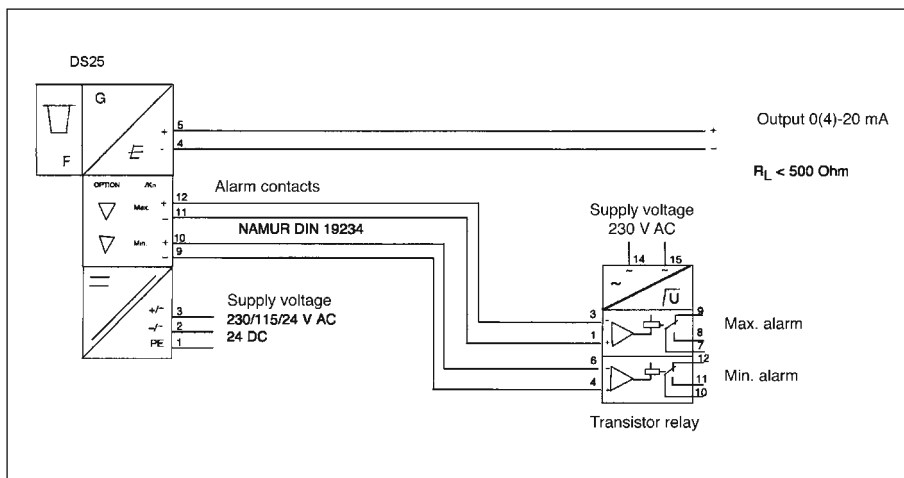

electronic transducer,  
4-wire

2 alarm contacts with  
contact protection relay

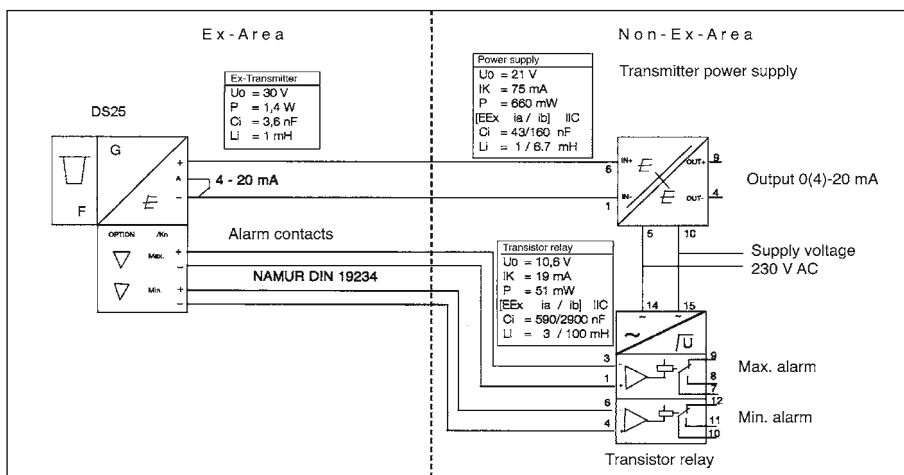

EEx application:

electronic transducer [EEx],  
2-wire

2 alarm contacts with  
contact protection relay