

# DR12

## Precision Turbine Flowmeter for Thin, Non-Viscous Liquids

- Wetted parts made completely of stainless steel
- Measuring accuracy:  $\pm 0.5\%$  to  $\pm 1\%$  of measured value
- Nominal diameters: 3/8" to 16" / DN10 to DN400 for flows up to 17600 GPM / 4,000 m<sup>3</sup>/h
- Available for pressures up to 5800 psi / 400 bar and temperatures up to 300 °F / 150°C
- Available with threaded or flange connection

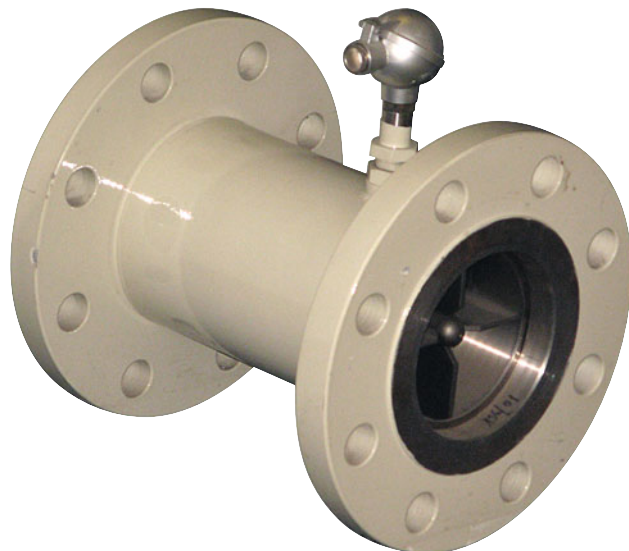

### Description:

Model DR12 flowmeters are sturdy turbine-type flow sensors suitable for mobile or permanent installation. A turbine wheel set in motion by a flow parallel to its axis rotates at a speed proportional to the average speed of flow in the piping system. The movement of the turbine wheel is detected by a contactless pickup (coil). The resulting output frequency is a reliable indicator of the flow volume. The turbine body and the measuring unit are made of stainless steel: The bearing is made either of tungsten carbide or teflon. These flow sensors are available with male threaded (max. 2") or flanged connections (max. 16" / DN400).

### Typical Applications:

Model DR12 turbine flowmeters are primarily used to detect and measure the flow of thin, non-viscous liquids. The high-quality materials used in their construction, their ability to withstand high pressures as well as the broad selection of measuring ranges make these devices ideal for use in the greatest variety of applications, including but by no means limited to, engineering, machinery construction and in the chemical, pharmaceutical as well as the food and beverage industries.

## Models:

Model DR12 turbine flowmeters come standard with a housing of stainless steel AISI 321 / 1.4541.

For sizes up to 3" / DN80, the rotor is made of stainless steel AISI 420 / 1.4034. For larger sizes, the rotor is made of stainless steel AISI 321 / 1.4541.

The standard bearings are made of tungsten carbide. PTFE bearings are optionally available.

Sensors with flange connections come standard with flanges made of steel grade AISI 5LX / 1.1106. Flanges made of stainless steel AISI 321 / 1.4541 are optionally available.

The flanges are welded to the sensor body in a manner that ensures that they do not come in contact with the liquid being monitored.

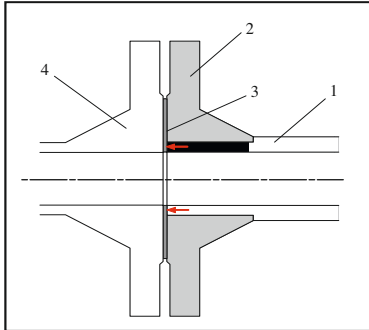

- 1 = DR12 stainless steel housing
- 2 = Steel flange
- 3 = Gasket
- 4 = Mating flange

## Sensor Systems

The following sensor systems are available for the DR12:

- Coil (self-excited),  
Output: Sinusoidal signal, 2-wire, 40 to 400 mV<sub>eff</sub>
- Coil with preamplifier  
Output: Rectangular pulse signal, 3-wire  
PNP open collector, short-circuit-proof  
Power supply: 10 to 30 VDC
- Coil with preamplifier (as per NAMUR)  
Output: Pulse signals, 2-wire  
Power supply: 8 VDC

If desired, these devices can be fitted with different types of electrical connectors.

- Plug connector (Hirschmann)  
 $T_{max} = -40$  to  $+230$  °F /  $-40$  to  $+110$  °C
- Plug connector (Cannon)  
 $T_{max} = -58$  to  $+300$  °F /  $-50$  to  $+150$  °C
- Connection head with terminal block  
 $T_{max} = -58$  to  $+300$  °F /  $-50$  °C to  $+150$  °C

## Output Signal

DR12 flowmeters provide an output frequency proportional to the flow rate. This output frequency is converted into a typical pulse/liter figure for each measuring range (see "Measuring Ranges" table).

Due to the production tolerances, the final pulse/liter ratings for identical ranges may vary by up to 10% among individual units. For this reason, every turbine is individually calibrated before delivery and provided with its own pulse/liter rating.

## Application Information

To ensure problem-free function, there are several factors to keep in mind when using DR12 turbine flow sensors:

### Chemical Resistance:

DR12 flow sensors can be used in all types of liquids that will not corrode the stainless steels used in their construction or the materials used in their turbine bearings.

### Viscosity:

In general, the operation of turbine-type flow sensors is affected by liquid viscosity. However, their design will provide problem-free service with liquids having a viscosity of at most 15 cSt. Any additional output errors resulting from use in higher-viscosity liquids will be less than 0.5%

### Gas Cavities:

Gas cavities (cavitation) in the liquids being monitored should be absolutely prevented from occurring. Such cavities can result in (additional) measurement errors. These measurement errors will correspond approximately to the volume of the gas bubbles being transported in the liquid.

### Contamination:

The amount of solid materials in the liquid being monitored may be at most 50 g/m<sup>3</sup> without affecting the measurement accuracy or the service life of the device. 80% of this solid materials should have a particles size no larger than 50µ; the remaining 20% should be no larger than 500 µ. Filament-shaped ("stringy") contamination in the liquid must be absolutely prevented from occurring since this type of material can accumulate and cause the rotor to lock up.

## Installation Information:

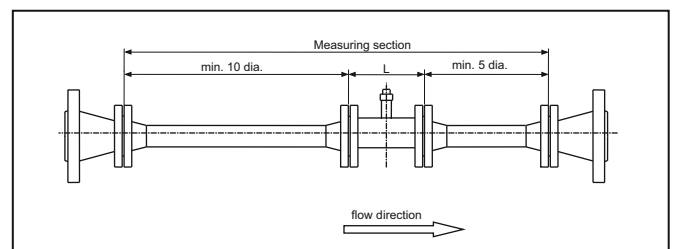

## Measuring Ranges:

Code	Measuring-range (water)		ID (inch / mm)	Pulses per Liter (psi / bar)	Pressure-loss	Signal-level (coil) mV <sub>eff</sub>
	GPM	m <sup>3</sup> /h				
1	0.25-1.25	0,055...0,275	0.24 / 6	17000	5.8 / 0.4	40
2	0.5-2.5	0,11...0,55	0.24 / 6	8500	5.8 / 0.4	40
3	1-5	0,22...1,1	0.47 / 12	4090	5.1 / 0.35	60
4	2-10	0,44...2,2	0.59 / 15	1960	5.1 / 0.35	80
5	3.5-17.5	0,8...4	0.59 / 15	1080	5.1 / 0.35	80
6	7-35	1,6...8	0.71 / 18	562	5.1 / 0.35	200
7	14-70	3,2...16	0.98 / 25	259	4.4 / 0.3	200
8	30-150	6,8...34	1.46 / 37	95,3	4.4 / 0.3	250
9	60-300	13,6...68	1.97 / 50	60,88	4.4 / 0.3	300
10	120-600	27...135	2.95 / 75	16	4.4 / 0.3	400
11	240-1200	54...270	3.94 / 100	12	3.6 / 0.25	200
12	480-2400	110...550	5.91 / 150	5,236	3.6 / 0.25	200
13	960-4800	220...1100	7.87 / 200	3,109	3.6 / 0.25	200
14	1670-8350	380...1900	9.84 / 250	1,8	3.6 / 0.25	200
15	2380-11900	540...2700	11.81 / 300	1,267	3.6 / 0.25	200
16	3500-17500	800...4000	15.75 / 400	0,9	3.6 / 0.25	200

## Process Connection:

ID (inch / mm)	Type of Connection		
	Male thread NPT or G	Flange connection	
		ANSI	DIN
0.24 / 6	3/8"	3/8" RF	DN10
0.47 / 12	1/2"	1/2" RF	DN15
0.59 / 15	5/8"	1/2" RF	DN15
0.71 / 18	3/4"	3/4" RF	DN20
0.98 / 25	1"	1" RF	DN25
1.46 / 37	1 1/2"	1 1/2" RF	DN40
1.97 / 50	2"	2" RF	DN50
2.95 / 75	-	3" RF	DN80
3.94 / 100	-	4" RF	DN100
5.91 / 150	-	6" RF	DN150
7.87 / 200	-	8" RF	DN200
9.84 / 250	-	10" RF	DN250
11.81 / 300	-	12" RF	DN300
15.75 / 400	-	16" RF	DN400

## Pressure Rating:

Nominal size	Pressure rating (bar)		
	Thread NPT or G	DIN Flange (PN)	ANSI Flange (lbs.)
DN10 / 3/8"	3600 / 250	40 / 160 / 250	150 / 300
-	(2300 / 160 for 5/8")	150 / 300	/ 600 / 900
DN15 / 5/8"		320 / 400	/ 1500 / 2500
DN20 / 3/4"	1450 / 100	40	150 / 300
DN25 1"	1450 / 100	40 / 160	150 / 300
-	/ 250 / 320 / 400	/ 600 / 900	
DN40 / 1 1/2"			/ 1500 / 2500
DN50 / 2"	1450 / 100	40 / 64	150 / 300
	/ 100 / 160 / 250	/ 600 / 900	
	/ 320 / 400	/ 1500 / 2500	
DN80 / 3"	-	10 / 40	150 / 300
	/ 64 / 100 / 160	/ 600 / 900	
	/ 250 / 320 / 400	/ 1500 / 2500	
DN100 / 4"	-	16 / 40	150 / 300
	/ 64 / 100	/ 600 / 900	
	/ 160 / 250	/ 1500 / 2500	
DN150 / 6"	-	16 / 40	150 / 300
	/ 64 / 100	/ 600 / 900	
	/ 160	/ 1500	
DN200 / 8"	-	16 / 40	150 / 300
-	/ 64	/ 600 / 900	
DN400 / 16"			

## Ordering Code:

Order Number: DR12. V. 09. 050D40. H. V. 0

Precision Turbine Flow Sensor

### Models:

R = Stainless steel housing, threaded  
 S = Stainless steel housing, steel flanges  
 V = Stainless steel housing, stainless steel flanges

### Measuring range:

01 to 16 = see "Measuring Range" table

### Process connection:

See separate "Process Connection" ordering code below

### Bearing:

H = Tungsten-carbide bearing  
 (not for measuring ranges 01 + 02)

P = PTFE bearing

### Sensor system with plug connector (Hirschmann):

S = coil, self-exciting, no preamplifier

V = coil with preamplifier, 3-wire, 10 to 30 VDC

N = coil with preamplifier as per NAMUR, 8 VDC

### Options:

0 = None

C = Plug connector (Cannon), -58 to +300 °F / -50 to +150°C

B = Connection head with terminal block, -58 to +300 °F / -50 to +150°C

9 = Please specify in writing.

## Ordering Code for Process Connections

Connection code: 50 D 40

### Nominal size:

010 = 3/8" / DN10

015 = 1/2" / DN15

018 = 5/8" / DN15

020 = 3/4" / DN20

025 = 1" / DN25

040 = 1 1/2" / DN40

050 = 2" / DN50

080 = 3" / DN80

100 = 4" / DN100

150 = 6" / DN150

200 = 8" / DN200

250 = 10" / DN250

300 = 12" / DN300

400 = 16" / DN400

### Type of connection (see "Process Connection" table):

G = male thread, G

N = male thread, NPT

D = DIN flange

A = ANSI flange

S = Special connection

### Pressure rating (see "Pressure Rating" table):

10 to 250 = 10 to 250 bar (for DIN flanges only)

150 to 2500 = 150 to 2500 lbs. (for ANSI flanges only)

320 = Special model rated at 320 bar

(only with "S" metric high pressure (S) threaded connection for measuring ranges 01 to 07)



## Technical Specifications:

### Materials:

- Housing:** stainless steel AISI 321 / 1.4541
- Rotor:** up to DN80: stainless steel AISI 420 / 1.4034  
from DN100: stainless steel AISI 321 / 1.4541
- Bearing:** tungsten carbide, PTFE optional
- Flanges:** steel AISI 5LX / 1.1106, stainless steel AISI 321 / 1.4541 optional

**Max. pressure:** as per "Pressure Rating" table and model coding

**Liquid temperature:** -58 to +300 °F / -50 to +150°C  
(-40 to +230 °F / -40 to +110°C with Hirschman plug connection)

**Ambient temperature:** -40 to +140 °F / -40 to +60°C

### Accuracy:

- DR12...01 to 03: ± 1% of measured value  
DR12...04 to 16: ± 0.5% of measured value

### Supply voltage:

- DR12...S: coil without preamplifier, self-exciting  
DR12...V: coil with preamplifier: 10 to 30 VDC  
DR12...N: coil with preamplifier (as per NAMUR) 8 VDC

## Dimensions:

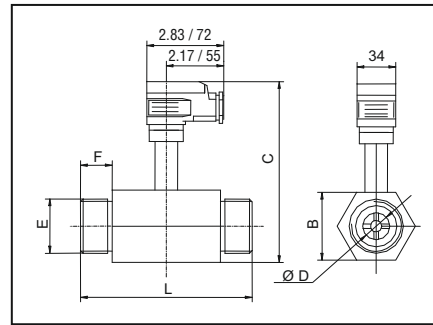

**Threaded connection:**

Inner diameter ØD (inch / mm)	B (inch / mm)	C (inch / mm)	L (inch / mm)	E (male thread, NPT or G)	F (inch / mm)
0.24 / 6	0.98 / 25	3.23 / 82	2.00 / 50.8	3/8"	0.50 / 12.7
0.47 / 12	0.98 / 25	3.39 / 86	2.50 / 63.5	1/2"	0.75 / 19
0.59 / 15	0.98 / 25	3.43 / 87	2.50 / 63.5	5/8"	0.75 / 19
0.71 / 18	1.50 / 38	3.50 / 89	3.25 / 82.6	3/4"	0.87 / 22
0.98 / 25	1.50 / 38	3.62 / 92	3.50 / 89.0	1"	0.90 / 23
1.46 / 37	2.20 / 56	3.90 / 99	4.50 / 114	1 1/2"	1.10 / 28
1.97 / 50	2.75 / 70	4.10 / 104	5.25 / 133	2"	1.16 / 29.5

Dimensions for metric high-pressure (S) threaded connections available on request.

## Electrical Connection:

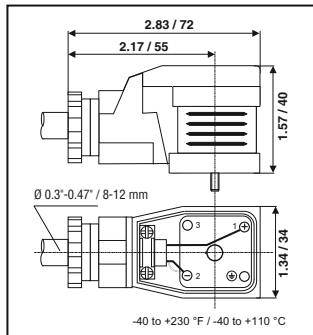

**Plug connection (Hirschmann)**

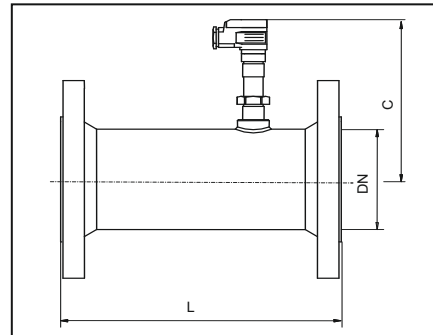

**Flange connection**

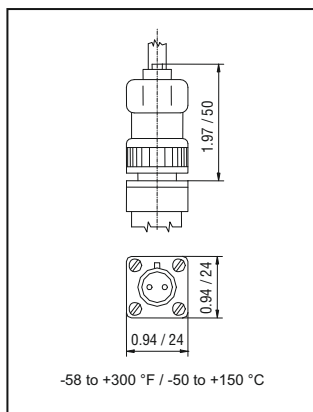

**Plug connection (Cannon)**

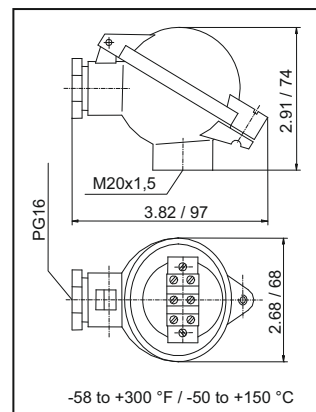

**Terminal connector housing**

Inner diameter ØD (inch / mm)	C (inch / mm)	L (inch / mm)	Inner diameter ØD (inch / mm)	C (inch / mm)	L (inch / mm)
0.24 / 6	3.74 / 95	4.50 / 114	3.15 / 80	5.51 / 140	9.00 / 228
0.47 / 12	4.02 / 102	5.00 / 127	3.94 / 100	6.06 / 154	14.00 / 355
0.59 / 15	4.53 / 115	5.00 / 127	5.91 / 150	7.09 / 180	14.50 / 368
0.71 / 18	4.53 / 115	5.55 / 141	7.87 / 200	9.30 / 236	18.00 / 458
0.98 / 25	4.96 / 126	6.00 / 153	9.84 / 250	10.43 / 265	18.00 / 458
1.46 / 37	4.96 / 126	7.00 / 179	11.81 / 300	11.42 / 290	18.00 / 458
1.97 / 50	5.20 / 132	7.80 / 198	15.75 / 400	13.58 / 345	24.00 / 610

Dimensions apply to DIN flanges.

Dimensions for ANSI flanges may be slightly different.

PKP Prozessmesstechnik GmbH

Borsigstraße 24 · D-65205 Wiesbaden

+49 (0) 6122-7055-0 · +49 (0) 6122-7055-50  
Email: info@pkp.de · Internet: www.pkp.de

PKP Process Instruments Inc.

10 Brent Drive · Hudson, MA 01749

+1-978-212-0006 · +1-978-568-0060  
Email: info@pkp.eu · Internet: www.pkp.eu

