

# DB08

## Thermal Mass Flow Meter

- **Stainless steel sensor, also suitable for corrosive gases**
- **Measuring ranges: from 5...100 ml/min to 375...7500 l/min**
- **Measuring system unaffected by temperature and pressure**
- **High accuracy**
- **Direct-flow method, low sensitivity to contamination and moisture**



### Description:

The DB08 thermal mass flow meter is a modular measuring system for detecting the mass flow of gases. The device generates a voltage output (0...5 VDC) or a current output (4...20 mA) based on the amount of flow.

### Typical Applications:

Because it has a modular design, can be installed in any position and is extremely easy to clean without requiring recalibration, the DB08 is suitable for use in numerous applications, such as in analytical devices, in the semiconductor industry, in compressed-air systems, laser systems, welding systems or fuel cells. Depending on its intended use, the DB08 can be supplied with an aluminum or stainless steel housing.

## Dimensions:

No.	Models	A	B	C	D	F	G	H
1	DB08.x.08-...	95	G 1/4	G1/4	30	90	92	35
2	DB08.x.15-15 to DB08.x.15-45	95	G1/2	G1/2	30	90	92	35
3	DB08.x.15-55 to DB08.x.15-26	116	G1/2	G1/2	50	123	125	35
4	DB08.x.25-36 to DB08.x.25-56	116	G1	G1	70	141	143	35
5	DB08.x.25-66 to DB08.x.25-76	143	G1	G1	110	171	173	35

Pos. 1 and 2

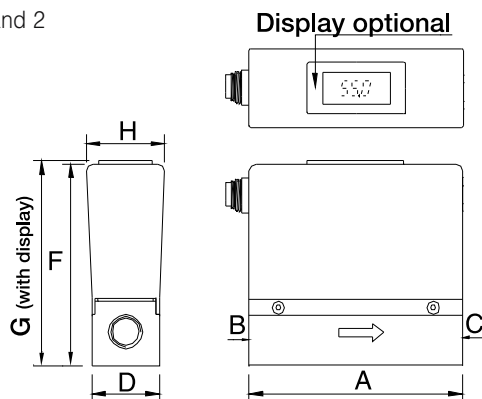

Pos. 3, 4 and 5

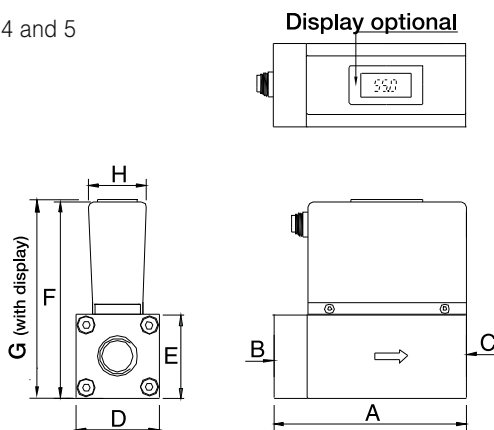

## Technical Specifications:

**Voltage supply:** 24 VDC +/- 10 %

**Maximum current values:**

Up to measuring range 08-14: 75 mA max.

As of measuring range 08-24:

Switch-on current: 250 mA max.

Without flow: 75 mA max.

100 % flow: 175 mA max.

**Output:** 0...5 VDC or 4...20 mA

## Model Key:

**Order Number:** DB08. E. 08-12. L. A. 0

**Thermal Mass Flow Meter**

### Materials:

A = Aluminum housing (anodized)

E = Stainless steel housing, 1.4435/1.4404

### Measuring Ranges: (Air)

Measuring system: bypass

08-12 = 0.005 to 0.1 NI/min,

08-22 = 0.010 to 0.2 NI/min,

08-52 = 0.025 to 0.5 NI/min,

08-13 = 0.05 to 1 NI/min,

08-23 = 0.1 to 2 NI/min,

08-53 = 0.25 to 5 NI/min,

08-14 = 0.5 to 10 NI/min,

G 1/4 female thread

G 1/4 female thread

G 1/4 female thread

G 1/4 female thread

G 1/4 female thread

G 1/4 female thread

G 1/4 female thread

Measuring system: direct flow

08-24 = 1 to 20 NI/min,

08-54 = 2.5 to 50 NI/min,

08-15 = 5 to 100 NI/min,

15-15 = 5 to 100 NI/min,

15-25 = 10 to 200 NI/min,

15-45 = 20 to 400 NI/min,

15-55 = 25 to 500 NI/min,

15-16 = 50 to 1000 NI/min,

15-26 = 100 to 2000 NI/min,

25-36 = 150 to 3000 NI/min,

25-46 = 200 to 4000 NI/min,

25-56 = 250 to 5000 NI/min,

25-66 = 300 to 6000 NI/min,

25-76 = 375 to 7500 NI/min,

G 1/4 female thread

G 1/4 female thread

G 1/4 female thread

G 1/2 female thread

G 1/2 female thread

G 1/2 female thread

G 1/2 female thread

G 1/2 female thread

G 1/2 female thread

G 1 female thread

G 1 female thread

G 1 female thread

G 1 female thread

G 1 female thread

### Media:

L = Standard medium: Air

N2 = Standard medium: N<sub>2</sub>

O = Standard medium: O<sub>2</sub>

S = Pure gas calibration

### Output:

A = Analog output, 4 to 20 mA

V = Voltage output, 0 to 5 VDC

S = Special

### Special Features:

0 = None

1 = LCD display as flow meter

2 = LCD display as summation counter

99 = Please specify in writing.

## Technical Specifications:

**Max. pressure:** 10 bar (optional 40 bar only for DB08.E)

**Max. media temperature:** 0 to 70°C

**Accuracy:** +/- 3% of end value for air

**Repeatability:** +/- 0.5% of end value

**Protection type:** IP 40

**Connection:** 6-pin DIN plug

**Time-constant sensor:** 0.7 sec (63.2%)

## Materials:

**Sensor:** 1.4435/1.4404

**Device housing:** 1.4435/1.4404 or anodized aluminum

**Strainer/retaining ring:** Stainless steel/PTFE

**Gaskets:** Viton (standard), other materials available upon request

PKP Prozessmesstechnik GmbH

Borsigstraße 24 · D-65205 Wiesbaden

+49 (0) 6122-7055-0 · +49 (0) 6122-7055-50

Email: info@pkp.de · Internet: www.pkp.de

PKP Process Instruments Inc.

10 Brent Drive · Hudson, MA 01749

+1-978-212-0006 · +1-978-568-0060

Email: info@pkp.eu · Internet: www.pkp.eu

