



PKP Prozessmesstechnik GmbH

Borsigstrasse 24

D-65205 Wiesbaden-Nordenstadt

Tel: 06122 / 7055 - 0

Fax: 06122 / 7055 – 50

Operating Instructions

PDR04

Differential pressure gauge with double, linked Bourdon tubes

INSTRUCTION LEAFLET FOR PRESSURE GAUGES

WARNING:

Incorrect use of pressure gauges can cause damage and injuries. Under this Directive, the user must ensure that pressure gauges are installed and used in such a way that pressure-related hazards are eliminated to a maximum extent.

Before starting installation, follow the recommendations of standard EN 837-2:

- Check that the pressure gauge, designed in compliance with standard EN 837-1/3, is suitable for the planned use in terms of:
 - Operating pressure (OP)
 - Operating temperature (OT)
 - Safety level of the pressure gauge
 - Connection interface
 - Type of mounting
 - Compatibility of materials in contact with the fluid to be measured
 - Environmental conditions, vibrations, shocks, pulses, ambient atmosphere
 - Check that the pressure gauge is compatible with the surrounding atmosphere

USE IN AN OXYGEN CIRCUIT

Check that the pressure gauge is designed for such an application. The dial must have the word OXYGEN printed in red and the international symbol "oil-free" (a crossed-out burette). The pressure gauge must not have been in contact with oil or grease that is incompatible with oxygen:
RISK OF EXPLOSION!

Mounting

A pressure gauge must be mounted in compliance with standard practice.

- We advise to mount with an isolation valve.
- The user must check that the connections are perfectly sealed by using suitable seals that are compatible with the fluid to be measured.
- Use a correctly sized spanner to tighten connections. NEVER TWIST THE CASE IN ORDER TO TIGHTEN CONNECTIONS.
- Comply with the instructions given on the device when putting it into service.
- For pressure gauges fitted with a rear blow-out disc for protection against overpressure, ensure that there is a gap of at least 10 mm between the rear panel of the casing and the panel immediately next to it.
- Likewise, for this type of rear blow-out disc and a casing filled with damping fluid, do not remove the disc from its location.
- Only re-use a pressure gauge if the medium is the same as for its first use.

USE

Warning: The operating conditions must be such that the device can be used safely.

THE PRESSURE GAUGE MUST NOT BE SUBJECTED TO:

- Mechanical shocks: if there is a risk install it at a distance with a hose connection.
- Vibrations: if there is a risk install it at a distance with a hose connection or use a liquid filled pressure gauge.
- Pressure pulses: if there is a risk mount a pulsation damper.

Warning: pressure pulses cause a considerable shortening of the operating life of pressure gauges.

- Pressures greater than operating pressures (OP). Otherwise use a pressure relief valve.
- Temperatures greater or less than operating temperatures (OT). If there is a risk use a siphon mount or mount with hose connection to respect the temperature at the pressure gauge.

NOTE:

Failure to observe the conditions above may reduce pressure gauge safety. In such cases contact us.

DISASSEMBLY

- During disassembly, check that the pressure gauge is no longer under pressure. As a precaution, disassemble it slowly.
- Check that the temperature of the pressure gauge body is not sufficient to cause burning.
- Check that residues of the product present in the tube and block of the pressure gauge are not dangerous for the operator and the environment.

MAINTENANCE

- The general safety of a facility often depends on the reliability of indications on the pressure gauges installed in the facility.
- Any pressure gauge that seems to be giving false readings must be removed immediately, then tested. If the tests prove it is unreliable, it must be replaced with a new device.
- Periodic verifications should be carried out to check the accuracy of pressure gauges.
- Any pressure gauge considered to have been subjected to abnormal conditions of use (e.g. fire, wrong fluid, blows, etc.) must not be used.

MAINTENANCE, VERIFICATION OR RECALIBRATION MUST BE CARRIED OUT BY PERSONNEL APPROVED BY THE CONSTRUCTOR AND USING SUITABLE EQUIPMENT.

IMPORTANT

The instructions in this leaflet must be strictly followed.

The manufacturer declines all responsibility for any direct or indirect damage to property or persons as well as for the consequence, for example, of lost production resulting from failure to observe the instructions in this leaflet.

PDR04

Differential pressure gauge with double, linked Bourdon tubes

- Made completely of stainless steel, fully welded design
- Available measuring ranges: from 0–0.6 bar to 0–16 bar
- Static pressure: 3–40 bar
- Housing diameter: 100 or 160 mm
- Designs for all types of installations available
- Limit contacts optionally available



Description:

Model PDR04 differential pressure gauges feature two Bourdon tube measurement systems that are linked to each other in a manner that causes only the pressure difference between the two inlets to be indicated by the movement of the needle relative to the gauge scale.

This design makes an additional rotary scale, such as used on other double-Bourdon-tube systems, unnecessary.

These devices are made completely of stainless steel and available in housing diameters of 100 mm or 160 mm.

Housing designs are available for essentially all possible types of installations. The gauges are also optionally available with limit contacts.

Typical Applications:







Model PDR04 differential pressure gauges are primarily used in the following areas of application:

- Filter monitoring
- Petrochemical industry
- Ship building
- Off-shore facilities
- Flow measurement by means of orifice plates or based on the differential-pressure principle

Models:

Nominal size:	Housing diameter of 100 or 160 mm
Materials:	Housing made of stainless steel 1.4301, Bourdon tubes and process connection made of stainless steel 1.4571
Process connection:	2 x 1/2" straight connections, male thread or 2 x 1/2" NPT connections, male thread; special-order connections optionally available
Designs:	
Version K:	for mounting on piping, connection on bottom
Version L:	for surface mounting with rim flange on back side, connection on bottom
Version M:	for mounting on piping, connection on back
Version N:	for panel mounting, with three-hole bezel, connection on back
Version O:	for panel mounting, with three-hole bezel, connection on bottom
Version M:	for panel mounting, with bezel and retainer, connection on back

Measuring Ranges:

Measuring range in bar (max. static pressure, on both sides)	Designs					
						
	Ordering codes					
0...0.6 (3 bar)	K67	L67	M67	N67	O67	H67
0...1 (4 bar)	K69	L69	M69	N69	O69	H69
0...1.6 (6 bar)	K70	L70	M70	N70	O70	H70
0...2.5 (10 bar)	K72	L72	M72	N72	O72	H72
0...4 (16 bar)	K73	L73	M73	N73	O73	H73
0...6 (25 bar)	K74	L74	M74	N74	O74	H74
0...10 (30 bar)	K75	L75	M75	N75	O75	H75
0...16 (40 bar)	K76	L76	M76	N76	O76	H76

Principle of Operation:

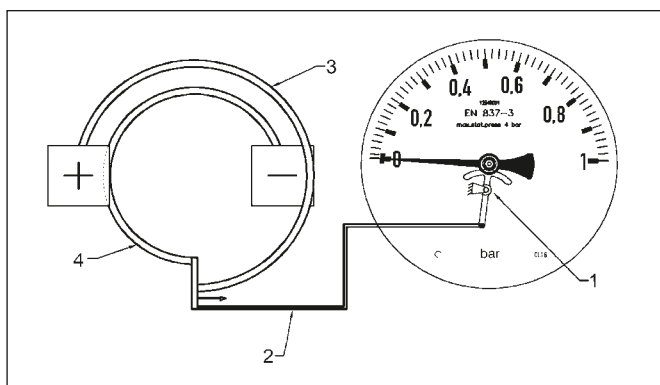

- 1 = Needle movement
- 2 = Mechanical linkage to measuring element
- 3 = Bourdon tube (+) for high pressure
- 4 = Bourdon tube (-) for low pressure

Model Coding:

Order Number: PDR04 10. E. 15G. 0. K75. 0. 0

Differential pressure gauge with double, linked Bourdon tubes

Models:

- 10 = Housing diameter of 100 mm
- 16 = Housing diameter of 160 mm

Materials:

- E = Completely of stainless steel

Process connection:

- 15G = 2 x 1/2" straight connections, male thread
- 15N = 2 x 1/2" NPT, male thread
- S = Special-order connection (see table in section "Options and Accessories")

Vibration dampening:

- 0 = None
- 1 = Glycerin-filled
- 2 = Oil-filled (only for devices with contact or analog output)

Designs and measuring ranges:

K67 to H76 = See table in section "Measuring Ranges"

Electrical accessories:

- 0 = None
- xxx = See table in section "Limit Contacts"

Options and accessories (more than one may be selected):

- 0 = None
- xxx = See table in section "Options and Accessories"

Technical Specifications:

Housing: Round gauge housing made of 1.4301 stainless steel, d = 100 or 160 mm

Pressure sensing element: 2 x Bourdon tubes made of stainless steel 1.4571

Needle movement: stainless steel 1.4301

Glass face: instrument glass (4 mm)

Scale and needle: aluminum, needle deflection 90°-180°

Process connection:

- 1/2" straight thread or NPT (standard)
- 1/4", 3/8" straight thread or NPT (optional), all made of stainless steel 1.4571
- Other connections available upon request

Liquid-filled version:

Glycerin (oil filled for gauges with contact devices)

Measuring ranges:

See table in section "Measuring Ranges"

Max. static pressure:

See table in section "Measuring Ranges"

Media temp.: -20° to +100°

Accuracy: Class 1.6

Protection type: IP45 (IP65 for filled devices)

PKP Prozessmesstechnik GmbH

Borsigstraße 24 · D-65205 Wiesbaden

+49 (0) 6122-7055-0 · +49 (0) 6122-7055-50

Email: info@pkp.de · Internet: www.pkp.de

PKP Process Instruments Inc.

10 Brent Drive · Hudson, MA 01749

+1-978-212-0006 · +1-978-568-0060

Email: info@pkp.eu · Internet: www.pkp.eu



Abmessungen:

PDR04...K
for mounting on piping, connection on bottom

	Housing diameter (mm)			
	100	160	100 + contact	160 + contact
A	101.5	162	101.5	162
B	97	100	159	163
C	14	18	14	18
E	90	120	90	120
T	20	20	20	20

PDR04...L
for surface mounting with rim flange on back side, connection on bottom

	Housing diameter (mm)			
	100	160	100 + contact	160 + contact
A	101.5	162	101.5	162
B	100	102	162	165
C	14	18	14	18
D	132	196	132	196
E	90	120	90	120
P	116	178	116	178
H	4.5	6	4.5	6
T	20	20	20	20

PDR04...M
for mounting on piping, connection on back

	Housing diameter (mm)			
	100	160	100 + contact	160 + contact
A	101.5	162	101.5	162
B	97	100	159	163
E	137	140	199	203
T	20	20	20	20

PDR04...N
for panel mounting, with three-hole bezel, connection on back

	Housing diameter (mm)			
	100	160	100 + contact	160 + contact
A	101.5	162	101.5	162
B	97	100	159	163
D	132	196	132	196
E	137	140	199	203
F	3,5	3	3,5	3
G	13	15,5	13	15,5
H	4,5	6	4,5	6
P	116	178	116	178
T	20	20	20	20

PDR04...O
for panel mounting, with three-hole bezel, connection on bottom

	Housing diameter (mm)			
	100	160	100 + contact	160 + contact
A	101.5	162	101.5	162
B	97	100	97	100
C	14	18	14	18
D	132	196	132	196
E	90	120	90	120
F	3.5	3	3.5	3
G	13	15.5	13	15.5
H	4.5	6	4.5	6
P	116	178	116	178
T	20	20	20	20

PDR04...H
for panel mounting, with bezel and retainer, connection on back

	Housing diameter (mm)			
	100	160	100 + contact	160 + contact
A	101.5	162	101.5	162
B	97	100	159	163
D	110	180	110	180
E	137	140	199	203
F	2	2	2	2
G	10.5	9	10.5	9
T	20	20	20	20

Limit switches:

Models:

Magnetic spring

contact:

as normally open contact (N/O)
or normally closed contact (N/C)
(max. 2 contacts)
as changeover contact (max. 1 contact)
breaking capacity: 30 W, 50 VA
switching voltage: 24–250 V

Inductive contact: as normally open contact (N/O) –
switched through output transistor
(enabled) or normally closed contact
(N/C) – output transistor disabled
(max. 2 contacts)
control voltage: 8 VDC, Ri = 1 kOhm
intrinsically safe as per EEx ib IIC T6

Description	Code
Contact operation with increasing pressure, needle movement clockwise (from left to right)	1 = normally open contact (N/O) 2 = normally closed contact (N/C) 3 = changeover contact
1 magnetic spring contact = normally open (N/O)	M1
1 magnetic spring contact = normally closed (N/C)	M2
1 magnetic spring contact = changeover, normally closed (N/C)	M3
2 magnetic spring contacts Switching function: x = normally open (N/O) or normally closed (N/C)	Mxx
1 inductive contact = normally open (N/O)	I1
1 inductive contact = normally closed (N/C)	I2
2 inductive contacts Switching function: x = normally open (N/O) or normally closed (N/C)	Ixx

Options and Accessories:

Description	Code
Scale in psi	P
Double scale in bar / psi	BP
Special-order scale	SK...
Process connection 1/4" straight thread	08G
Process connection 3/8" straight thread	10G
Process connection 1/4" NPT	08N
Process connection 3/8" NPT	10N
Three-valve manifold made of stainless steel Process connection: 2 x 1/4" straight connections, female thread Instrument connection: 2 x 1/2" straight connections with rotary sleeve clamp	3VD-35

Three-valve manifold for PDR04:

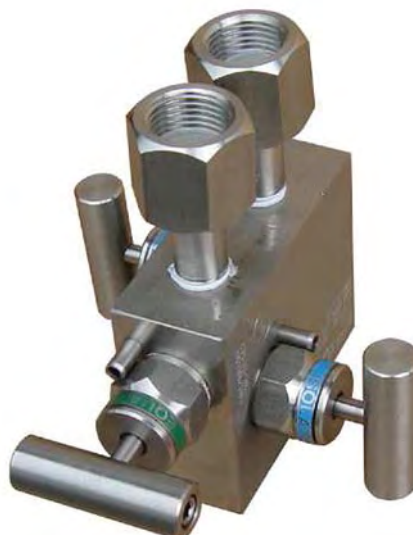

The model 3VD-35 valve manifold serves to block off the connection to the process as well as to provide pressure compensation between both inlets of the differential pressure gauge before the actual measurements are taken.

The device is made completely of stainless steel. The fitting packing consists of PTFE.

The valve manifold can be used for all differential pressure gauges with a minimum distance of 35 mm between the process connections.

Function:

