



*PKP Prozessmesstechnik GmbH*

*Borsigstrasse 24*

*D-65205 Wiesbaden-Nordenstadt*

*Tel: 06122 / 7055 - 0*

*Fax: 06122 / 7055 – 50*

## **Operating Instructions**

### **PDR02**

*Differential pressure gauge with double Bourdon tubes*

*for measuring relative and differential pressures*

# INSTRUCTION LEAFLET FOR PRESSURE GAUGES

## **WARNING:**

Incorrect use of pressure gauges can cause damage and injuries. Under this Directive, the user must ensure that pressure gauges are installed and used in such a way that pressure-related hazards are eliminated to a maximum extent.

*Before starting installation, follow the recommendations of standard EN 837-2:*

- Check that the pressure gauge, designed in compliance with standard EN 837-1/3, is suitable for the planned use in terms of:
  - Operating pressure (OP)
  - Operating temperature (OT)
  - Safety level of the pressure gauge
  - Connection interface
  - Type of mounting
  - Compatibility of materials in contact with the fluid to be measured
  - Environmental conditions, vibrations, shocks, pulses, ambient atmosphere
  - Check that the pressure gauge is compatible with the surrounding atmosphere

## **USE IN AN OXYGEN CIRCUIT**

Check that the pressure gauge is designed for such an application. The dial must have the word OXYGEN printed in red and the international symbol "oil-free" (a crossed-out burette). The pressure gauge must not have been in contact with oil or grease that is incompatible with oxygen:  
**RISK OF EXPLOSION!**

## **Mounting**

A pressure gauge must be mounted in compliance with standard practice.

- We advise to mount with an isolation valve.
- The user must check that the connections are perfectly sealed by using suitable seals that are compatible with the fluid to be measured.
- Use a correctly sized spanner to tighten connections. NEVER TWIST THE CASE IN ORDER TO TIGHTEN CONNECTIONS.
- Comply with the instructions given on the device when putting it into service.
- For pressure gauges fitted with a rear blow-out disc for protection against overpressure, ensure that there is a gap of at least 10 mm between the rear panel of the casing and the panel immediately next to it.
- Likewise, for this type of rear blow-out disc and a casing filled with damping fluid, do not remove the disc from its location.
- Only re-use a pressure gauge if the medium is the same as for its first use.

## **USE**

**Warning:** The operating conditions must be such that the device can be used safely.

**THE PRESSURE GAUGE MUST NOT BE SUBJECTED TO:**

- Mechanical shocks: if there is a risk install it at a distance with a hose connection.
- Vibrations: if there is a risk install it at a distance with a hose connection or use a liquid filled pressure gauge.
- Pressure pulses: if there is a risk mount a pulsation damper.

**Warning:** pressure pulses cause a considerable shortening of the operating life of pressure gauges.

- Pressures greater than operating pressures (OP). Otherwise use a pressure relief valve.
- Temperatures greater or less than operating temperatures (OT). If there is a risk use a siphon mount or mount with hose connection to respect the temperature at the pressure gauge.

## **NOTE:**

Failure to observe the conditions above may reduce pressure gauge safety. In such cases contact us.

## **DISASSEMBLY**

- During disassembly, check that the pressure gauge is no longer under pressure. As a precaution, disassemble it slowly.
- Check that the temperature of the pressure gauge body is not sufficient to cause burning.
- Check that residues of the product present in the tube and block of the pressure gauge are not dangerous for the operator and the environment.

## **MAINTENANCE**

- The general safety of a facility often depends on the reliability of indications on the pressure gauges installed in the facility.
- Any pressure gauge that seems to be giving false readings must be removed immediately, then tested. If the tests prove it is unreliable, it must be replaced with a new device.
- Periodic verifications should be carried out to check the accuracy of pressure gauges.
- Any pressure gauge considered to have been subjected to abnormal conditions of use (e.g. fire, wrong fluid, blows, etc.) must not be used.

**MAINTENANCE, VERIFICATION OR RECALIBRATION MUST BE CARRIED OUT BY PERSONNEL APPROVED BY THE CONSTRUCTOR AND USING SUITABLE EQUIPMENT.**

## **IMPORTANT**

The instructions in this leaflet must be strictly followed.

The manufacturer declines all responsibility for any direct or indirect damage to property or persons as well as for the consequence, for example, of lost production resulting from failure to observe the instructions in this leaflet.

# PDR02

## Differential pressure gauge with double Bourdon tubes for measuring relative and differential pressures

- Made completely of stainless steel, fully welded design
- Available measuring ranges: from -1...0 bar to 0...1600 bar
- Housing diameter: 100 or 160 mm
- Designs for all types of installations available



### Description:

Model PDR02 pressure gauges have two separate, independent Bourdon tube measuring systems, each with its own indicator needle. The two needles indicate their respectively measured pressure on the same gauge scale. These devices can be used to monitor two separate measurement points or to determine differential pressure, such as the pressure between the inlet and outlet of a filter. The differential pressure is indicated by difference between the readings shown by the two needles. As an option, the differential pressure can also be directly read by means of an additional rotary scale. These devices are made completely of stainless steel and available in housing diameters of 100 mm or 160 mm. Housing designs are available for essentially all possible types of installations.

### Typical Applications:

Model PDR02 differential pressure gauges are primarily used in the following areas of application:

- Filter monitoring
- Chemical and petrochemical industries
- Ship building
- General industrial applications

## Models:



**Nominal size:** Housing diameter of 100 or 160 mm  
**Materials:** Housing made of stainless steel 1.4301, Bourdon tubes and process connection made of stainless steel 1.4571

**Process connection:**  
 2 x G 1/2 connections, male thread  
 or 2 x 1/2" NPT connections, male thread

### Designs:

- Version K:** for mounting on piping, connection on bottom
- Version L:** for surface mounting with rim flange on back side, connection on bottom
- Version M:** for mounting on piping, connection on back
- Version N:** for panel mounting, with three-hole bezel, connection on back
- Version O:** for panel mounting, with three-hole bezel, connection on bottom
- Version M:** for panel mounting, with bezel and retainer, connection on back

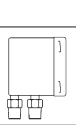
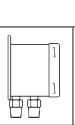
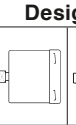
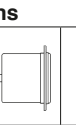
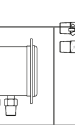
## Measuring ranges:

Measuring range in bar	Designs					
						
	Ordering codes					
-1 ... 0	K16	L16	M16	N16	O16	H16
-1 ... 0.6	K42	L42	M42	N42	O42	H42
-1 ... 1.5	K43	L43	M43	N43	O43	H43
-1 ... 3	K44	L44	M44	N44	O44	H44
-1 ... 5	K45	L45	M45	N45	O45	H45
-1 ... 9	K46	L46	M46	N46	O46	H46
-1 ... 15	K49	L49	M49	N49	O49	H49
-1 ... 24	K52	L52	M52	N52	O52	H52
0 ... 0.6	K67	L67	M67	N67	O67	H67
0 ... 1	K69	L69	M69	N69	O69	H69
0 ... 1.6	K70	L70	M70	N70	O70	H70
0 ... 2.5	K72	L72	M72	N72	O72	H72
0 ... 4	K73	L73	M73	N73	O73	H73
0 ... 6	K74	L74	M74	N74	O74	H74
0 ... 10	K75	L75	M75	N75	O75	H75
0 ... 16	K76	L76	M76	N76	O76	H76
0 ... 25	K78	L78	M78	N78	O78	H78
0 ... 40	K79	L79	M79	N79	O79	H79
0 ... 60	K80	L80	M80	N80	O80	H80
0 ... 100	K81	L81	M81	N81	O81	H81
0 ... 160	K82	L82	M82	N82	O82	H82
0 ... 250	K84	L84	M84	N84	O84	H84
0 ... 400	K86	L86	M86	N86	O86	H86
0 ... 600	K87	L87	M87	N87	O87	H87
0 ... 1000	K88	L88	M88	N88	O88	H88
0 ... 1600	K89	L89	M89	N89	O89	H89

**Rotary scale for direct reading of the differential pressure:**

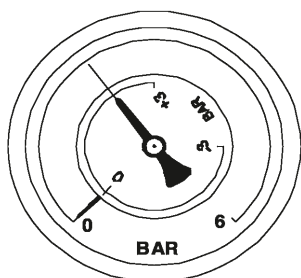

## Model Coding:

**Order Number:** PDR02 10. E. 15G. 0. K75. 0. 0

**Pressure gauge with double Bourdon-tube measuring system**

### Models:

10 = Housing diameter of 100 mm  
 16 = Housing diameter of 160 mm

### Materials:

E = Completely of stainless steel

### Process connection:

15G = 2 x G 1/2 connection, male thread  
 15N = 2 x 1/2" NPT, male thread  
 S = Special-order connection (see table "Options and Accessories")

### Vibration dampening:

0 = None  
 1 = Glycerin-filled

### Designs and measuring ranges:

K16 to H89 = See table "Measuring Ranges"

### Electrical accessories:

0 = None

### Options and accessories (more than one may be selected):

0 = None  
 xxx = See table "Options and Accessories"

## Technical Specifications:

**Housing:** Round gauge housing made of stainless steel 1.4301, d = 100 or 160 mm

### Pressure-responsive element:

2 x Bourdon tube made of stainless steel 1.4571

### Needle movement:

Brass

### Glass face:

Instrument glass (4 mm)

### Scale and needle:

Aluminum scale with white background and black graduations, black indicator needle

### Process connection:

1/2" G or NPT (standard)  
 1/4", 3/8" G or NPT (optional), all made of stainless steel 1.4571  
 Other connections available upon request

### Liquid-filled version:

Glycerin

### Measuring ranges:

See table "Measuring Ranges"

### Overload protection:

1.3 x end value

### Media temp.:

-20° to +100°C

### Accuracy:

Class 1.0

### Protection type:

IP65

## Options and Accessories:

Description:	Code
Scale in psi	P
Double scale in bar / psi	BP
Scale for differential pressure	SD
Special-order scale	SK...
Process connection G 1/4	O8G
Process connection G 3/8	10G
Process connection 1/4" NPT	O8N
Process connection 3/8" NPT	10N

PKP Prozessmesstechnik GmbH

Borsigstraße 24 · D-65205 Wiesbaden

+49 (0) 6122-7055-0 · +49 (0) 6122-7055-50

Email: info@pkp.de · Internet: www.pkp.de

PKP Process Instruments Inc.

10 Brent Drive · Hudson, MA 01749

+1-978-212-0006 · +1-978-568-0060

Email: info@pkp.eu · Internet: www.pkp.eu



## Dimensions:

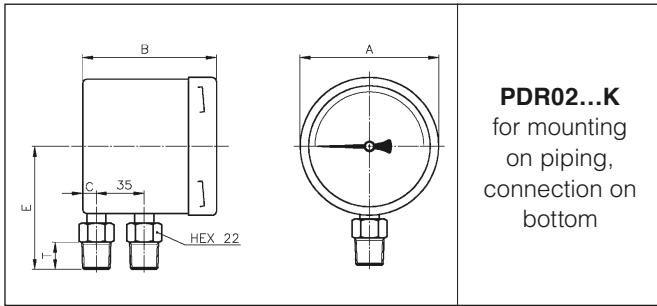

**PDR02...K**  
for mounting  
on piping,  
connection on  
bottom

	Housing diameter (mm)	
	100	160
A	101,5	162
B	97	100
C	14	18
E	90	120
T	20	20

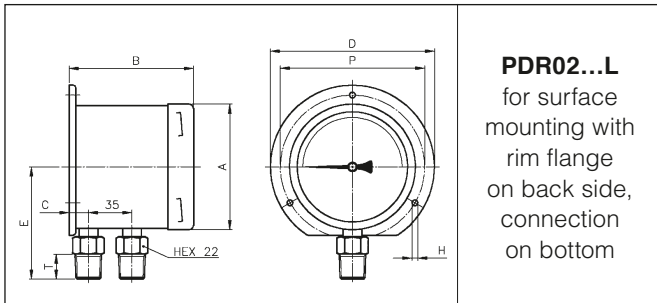

**PDR02...L**  
for surface  
mounting with  
rim flange  
on back side,  
connection on  
bottom

	Housing diameter (mm)	
	100	160
A	101,5	162
B	100	102
C	14	18
D	132	196
E	90	120
P	116	178
H	4,5	6
T	20	20

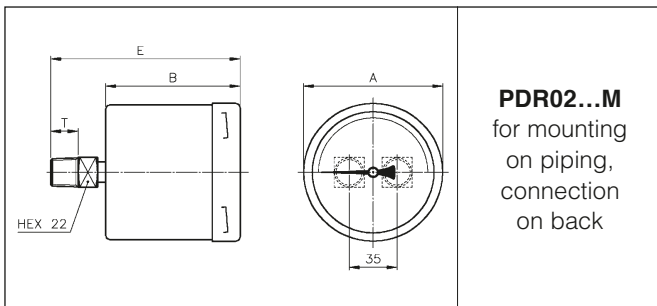

**PDR02...M**  
for mounting  
on piping,  
connection on  
back

	Housing diameter (mm)	
	100	160
A	101,5	162
B	97	100
E	137	140
T	20	20

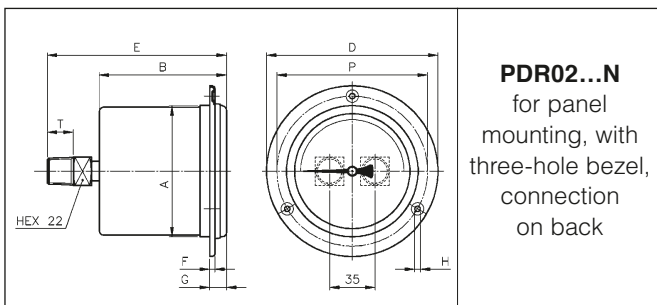

**PDR02...N**  
for panel  
mounting, with  
three-hole bezel,  
connection on  
back

	Housing diameter (mm)	
	100	160
A	101,5	162
B	97	100
D	132	196
E	137	140
F	3,5	3
G	13	15,5
H	4,5	6
P	116	178
T	20	20

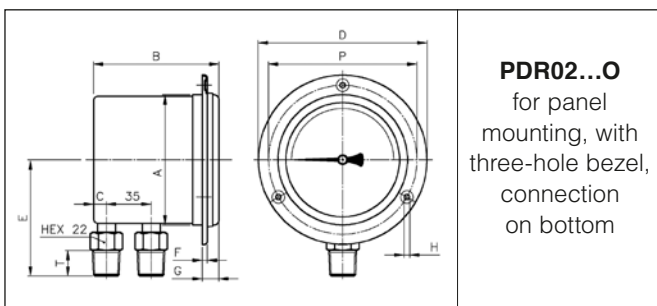

**PDR02...O**  
for panel  
mounting, with  
three-hole bezel,  
connection on  
bottom

	Housing diameter (mm)	
	100	160
A	101,5	162
B	97	100
C	14	18
D	132	196
E	90	120
F	3,5	3
G	13	15,5
H	4,5	6
P	116	178
T	20	20

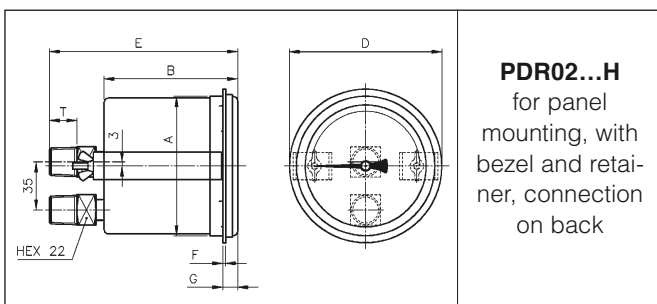

**PDR02...H**  
for panel  
mounting, with  
bezel and retain-  
er, connection  
on back

	Housing diameter (mm)	
	100	160
A	101,5	162
B	97	100
D	110	180
E	137	140
F	2	2
G	10,5	9
T	20	20

---

**PKP Prozessmesstechnik GmbH**   
Borsigstraße 24 · D-65205 Wiesbaden  
☎ +49 (0) 6122-7055-0 · 📠 +49 (0) 6122-7055-50  
Email: [info@pkp.de](mailto:info@pkp.de) · Internet: [www.pkp.de](http://www.pkp.de)

**PKP Process Instruments Inc.**   
10 Brent Drive · Hudson, MA 01749  
☎ +1-978-212-0006 · 📠 +1-978-568-0060  
Email: [info@pkp.eu](mailto:info@pkp.eu) · Internet: [www.pkp.eu](http://www.pkp.eu)

