



*PKP Prozessmesstechnik GmbH*

*Borsigstrasse 24*

*D-65205 Wiesbaden-Nordenstadt*

*Tel: 06122 / 7055 - 0*

*Fax: 06122 / 7055 – 50*

## **Operating Instructions**

### **PDP02**

*Differential pressure gauge with diaphragm  
measuring system and two measuring chambers*

# INSTRUCTION LEAFLET FOR PRESSURE GAUGES

## **WARNING:**

Incorrect use of pressure gauges can cause damage and injuries. Under this Directive, the user must ensure that pressure gauges are installed and used in such a way that pressure-related hazards are eliminated to a maximum extent.

*Before starting installation, follow the recommendations of standard EN 837-2:*

Check that the pressure gauge, designed in compliance with standard EN 837-1/3, is suitable for the planned use in terms of:

- Operating pressure (OP)
- Operating temperature (OT)
- Safety level of the pressure gauge
- Connection interface
- Type of mounting
- Compatibility of materials in contact with the fluid to be measured
- Environmental conditions, vibrations, shocks, pulses, ambient atmosphere
- Check that the pressure gauge is compatible with the surrounding atmosphere

## **USE IN AN OXYGEN CIRCUIT**

Check that the pressure gauge is designed for such an application. The dial must have the word OXYGEN printed in red and the international symbol "oil-free" (a crossed-out burette). The pressure gauge must not have been in contact with oil or grease that is incompatible with oxygen:  
**RISK OF EXPLOSION!**

## **Mounting**

A pressure gauge must be mounted in compliance with standard practice.

- We advise to mount with an isolation valve.
- The user must check that the connections are perfectly sealed by using suitable seals that are compatible with the fluid to be measured.
- Use a correctly sized spanner to tighten connections. NEVER TWIST THE CASE IN ORDER TO TIGHTEN CONNECTIONS.
- Comply with the instructions given on the device when putting it into service.
- For pressure gauges fitted with a rear blow-out disc for protection against overpressure, ensure that there is a gap of at least 10 mm between the rear panel of the casing and the panel immediately next to it.
- Likewise, for this type of rear blow-out disc and a casing filled with damping fluid, do not remove the disc from its location.
- Only re-use a pressure gauge if the medium is the same as for its first use.

## **USE**

**Warning:** The operating conditions must be such that the device can be used safely.

**THE PRESSURE GAUGE MUST NOT BE SUBJECTED TO:**

- Mechanical shocks: if there is a risk install it at a distance with a hose connection.
- Vibrations: if there is a risk install it at a distance with a hose connection or use a liquid filled pressure gauge.
- Pressure pulses: if there is a risk mount a pulsation damper.

**Warning:** pressure pulses cause a considerable shortening of the operating life of pressure gauges.

- Pressures greater than operating pressures (OP). Otherwise use a pressure relief valve.
- Temperatures greater or less than operating temperatures (OT). If there is a risk use a siphon mount or mount with hose connection to respect the temperature at the pressure gauge.

## **NOTE:**

Failure to observe the conditions above may reduce pressure gauge safety. In such cases contact us.

## **DISASSEMBLY**

- During disassembly, check that the pressure gauge is no longer under pressure. As a precaution, disassemble it slowly.
- Check that the temperature of the pressure gauge body is not sufficient to cause burning.
- Check that residues of the product present in the tube and block of the pressure gauge are not dangerous for the operator and the environment.

## **MAINTENANCE**

- The general safety of a facility often depends on the reliability of indications on the pressure gauges installed in the facility.
- Any pressure gauge that seems to be giving false readings must be removed immediately, then tested. If the tests prove it is unreliable, it must be replaced with a new device.
- Periodic verifications should be carried out to check the accuracy of pressure gauges.
- Any pressure gauge considered to have been subjected to abnormal conditions of use (e.g. fire, wrong fluid, blows, etc.) must not be used.

**MAINTENANCE, VERIFICATION OR RECALIBRATION MUST BE CARRIED OUT BY PERSONNEL APPROVED BY THE CONSTRUCTOR AND USING SUITABLE EQUIPMENT.**

## **IMPORTANT**

The instructions in this leaflet must be strictly followed.

The manufacturer declines all responsibility for any direct or indirect damage to property or persons as well as for the consequence, for example, of lost production resulting from failure to observe the instructions in this leaflet.

# PDP02

## Differential pressure gauge with diaphragm sensing system and two measuring chambers

- **Low-cost design**
- **Made completely of stainless steel, gaskets of Viton and PTFE**
- **Available measuring ranges: from 0–0.6 bar to 0–16 bar**
- **Max. static pressure: 20 bar**
- **High overload protection: max. 4 x measuring range end value**
- **Housing diameter: 100 or 160 mm**
- **Designs for all types of installations available**



### Description:

Model PDP02 differential pressure gauges have two measuring chambers, which are separated by a diaphragm. The difference in pressure between both chambers causes the diaphragm to deflect, the result of which is indicated by the movement of the needle relative to the gauge scale. These devices are made completely of stainless steel with gaskets of Viton and PTFE and available in housing diameters of 100 mm or 160 mm. Housing designs are available for essentially all possible types of installations.

### Typical Applications:

Model PDP02 differential pressure gauges are primarily used in the following areas of application:

- Filter monitoring
- Petrochemical industry
- Oil and gas systems
- Ship building
- Off-shore facilities
- General industrial applications
- Flow measurement by means of orifice plates or based on the differential-pressure principle

## Models:





**Nominal size:** Housing diameter of 100 or 160 mm  
**Materials:** Housing made of stainless steel 1.4301, process connection made of stainless steel 1.4571, diaphragm made of Duratherm

**Process connection:** 2 x G 1/2" or 2 x 1/2" NPT connections, male thread; special-order connections optionally available

### Designs:

**Version K:** for mounting on piping, connection on bottom  
**Version L:** for surface mounting with rim flange on back side, connection on bottom  
**Version M:** for mounting on piping, connection on back  
**Version N:** for panel mounting, with three-hole bezel, connection on back  
**Version O:** for panel mounting, with three-hole bezel, connection on bottom

## Measuring ranges:

Measuring range in bar (max. static pressure, on both sides) / overload protection in bar	Designs				
					
	Ordering codes				
0 ... 0.6 (20 / 2.4)	K67	L67	M67	N67	O67
0 ... 1 (20 / 4)	K69	L69	M69	N69	O69
0 ... 1.6 (20 / 6.4)	K70	L70	M70	N70	O70
0 ... 2.5 (20 / 10)	K72	L72	M72	N72	O72
0 ... 4 (20 / 16)	K73	L73	M73	N73	O73
0 ... 6 (20 / 20)	K74	L74	M74	N74	O74
0 ... 10 (20 / 20)	K75	L75	M75	N75	O75
0 ... 16 (20 / 20)	K76	L76	M76	N76	O76

## Principle of Operation:

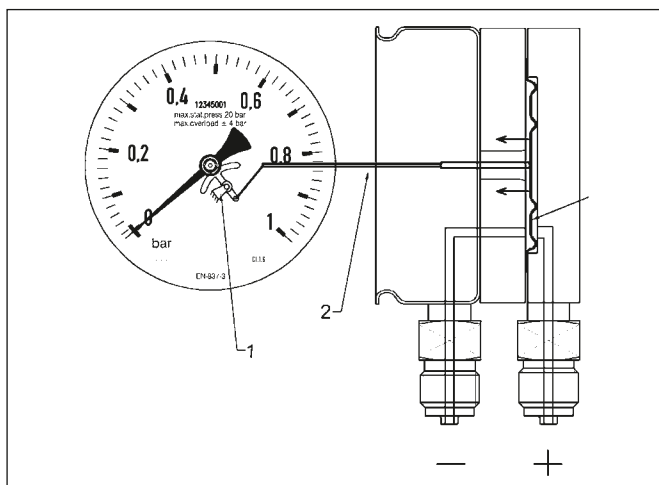

1 = Needle movement  
 2 = Mechanical linkage to measuring element  
 3 = Diaphragm

## Model Coding:

**Order Number:** PDP02 10. EV. 15G. 0. K75. 0. 0

**Differential pressure gauge with diaphragm sensor**

### Models:

10 = Housing diameter of 100 mm  
 16 = Housing diameter of 160 mm

### Materials:

E = Stainless steel, seals Viton/PTFE  
 S = Special order

### Process connection:

15G = 2 x G 1/2 male thread  
 15N = 2 x 1/2" NPT male thread  
 S = Special-order connection (see table "Options and Accessories")

### Vibration dampening:

0 = None

### Designs and measuring ranges:

K67 to O76 = See table "Measuring Ranges"

### Electrical accessories:

0 = None

### Options and accessories (more than one may be selected):

0 = None  
 xxx = See table "Options and Accessories"

## Technical Specifications:

**Housing:** Round gauge housing made of stainless steel 1.4301, d = 100 or 160 mm

**Pressure-responsive element:** Diaphragm made of Duratherm (NiCrCo alloy)

**Needle movement:** Brass, nickel-plated

**Glass face:** Instrument glass (4 mm)

**Scale and needle:** Aluminum

**Process connection:** 1/2" straight thread or NPT (standard), 1/4", 3/8" straight thread or NPT (optional), all made of stainless steel 1.4404. Other connections available upon request

**Gasket:** Viton/PTFE

**Measuring ranges:** See table "Measuring Ranges"

**Max. static pressure:** See table "Measuring Ranges"

**Overload protection:** See table "Measuring Ranges"

**Media temperature:** -20 °C to +80 °C

**Accuracy:** Class 2.5

**Protection type:** IP65

PKP Prozessmesstechnik GmbH 

Borsigstraße 24 · D-65205 Wiesbaden

+49 (0) 6122-7055-0 · +49 (0) 6122-7055-50

Email: info@pkp.de · Internet: www.pkp.de

PKP Process Instruments Inc. 

10 Brent Drive · Hudson, MA 01749

+1-978-212-0006 · +1-978-568-0060

Email: info@pkp.eu · Internet: www.pkp.eu



# Abmessungen:

**PDP02...K**  
for mounting  
on piping,  
connection on  
bottom

	Housing diameter (mm)	
	100	160
A	101.5	162
B	80	80
C	11	11
E	89	119
T	20	20

**PDP02...L**  
for surface  
mounting with  
rim flange on  
back side,  
connection on  
bottom

	Housing diameter (mm)	
	100	160
A	101.5	162
B	83	83
C	14	14
D	132	196
E	89	119
P	116	178
H	4.5	6
T	20	20

**PDP02...M**  
for mounting  
on piping,  
connection  
on back

	Housing diameter (mm)	
	100	160
A	101.5	162
B	80	80
E	120	120
T	20	20

**PDP02...N**  
for panel  
mounting, with  
three-hole bezel,  
connection  
on back

	Housing diameter (mm)	
	100	160
A	101.5	162
B	80	80
D	132	196
E	120	120
F	3.5	3
G	13	15.5
H	4.5	6
P	116	178
T	20	20

**PDP02...O**  
for panel  
mounting, with  
three-hole bezel,  
connection  
on bottom

	Housing diameter (mm)	
	100	160
A	101.5	162
B	80	80
C	11	11
D	132	196
E	89	119
F	3.5	3
G	13	15.5
H	4.5	6
P	116	178
T	20	20



## Three-valve manifold for PDP02:

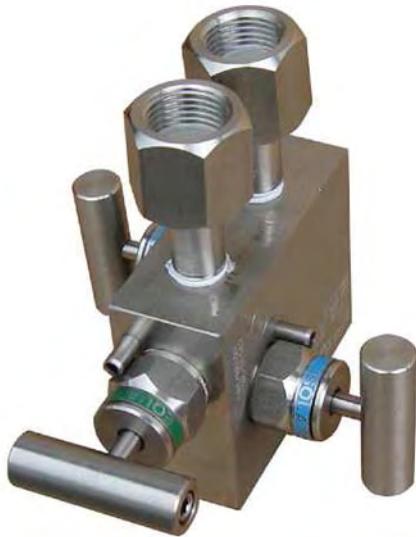

The model 3VD-35 valve manifold serves to block off the connection to the process as well as to provide pressure compensation between both inlets of the differential pressure gauge before the actual measurements are taken.

The device is made completely of stainless steel 1.4401.  
The fitting packing consists of PTFE.

The valve manifold can be used for all differential pressure gauges with a minimum distance of 35 mm between the process connections.

## Options and Accessories:

Description:	Code
Scale in psi	P
Double scale in bar / psi	BP
Special-order scale	SK...
Process connection G 1/4	08G
Process connection G 3/8	10G
Process connection 1/4" NPT	08N
Process connection 3/8" NPT	10N
Three-valve manifold made of stainless steel Process connection: 2 x G 1/4 female thread Instrument connection: 2 x G 1/2 with rotary sleeve clamp	3VD-35

## Function:

